

# eAssistant/TBK 3D CAD Plugin for Autodesk Inventor

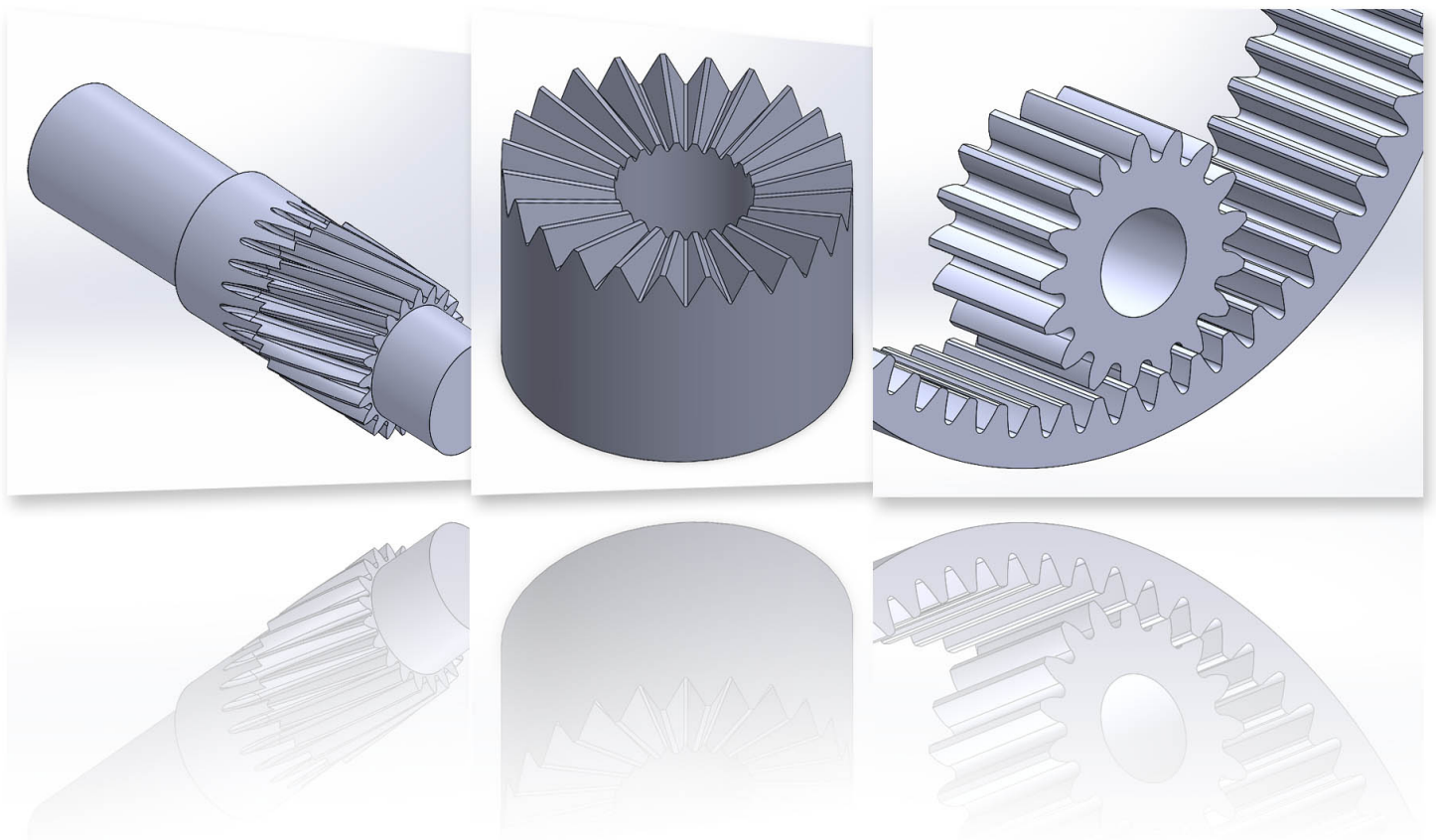

Release January 2026

# Contents

<b>1</b>	<b>eAssistant/TBK 3D CAD Plugin for Autodesk Inventor</b>	<b>3</b>
1.1	Installation	3
1.2	Start	3
1.3	Program Scope	4
1.4	Menu	4
1.4.1	Calculation	4
1.4.2	New Part	5
1.4.3	User Data (applies only for eAssistant)	6
1.4.4	Options	7
1.4.5	Help	8
1.5	Create a Shaft	9
1.6	Create a Cylindrical Gear	9
1.7	Create a Gearing on an Existing Part	10
1.8	Add Manufacturing Data to Engineering Drawing	11
1.8.1	Create User-defined Templates	12
1.9	Open a Calculation of an Active Part	14
1.10	Add a Tool Runout to the 3D Model	14
1.11	Bidirectional Connection between eAssistant/TBK and Autodesk Inventor	15
1.12	Create a Shaft in Autodesk Inventor and Import it into eAssistant/TBK	18

# Chapter 1

## eAssistant/TBK 3D CAD Plugin for Autodesk Inventor

### 1.1 Installation

Please start the installation file and follow the instructions. The CAD plugin will be installed on your system. Select 'eAssistant' or 'TBK' during installation depending on the product. Once the CAD plugin is installed, start Autodesk Inventor and open a new part. Now the top Autodesk Inventor menu bar provides the entry 'eAssistant' or 'TBK'.

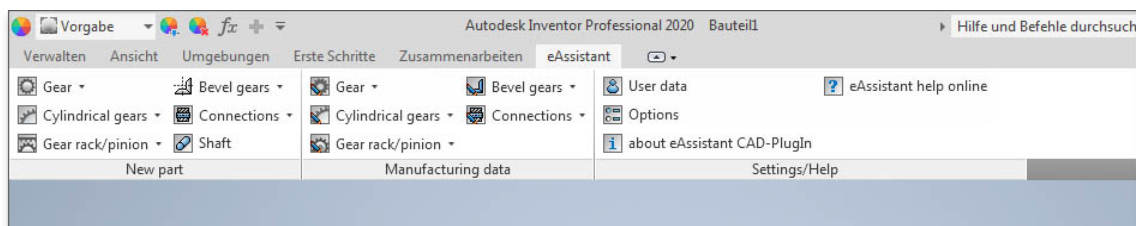

Figure 1.1: Installation

### 1.2 Start

Click the menu bar to use all functions of the CAD plugin in Autodesk Inventor.

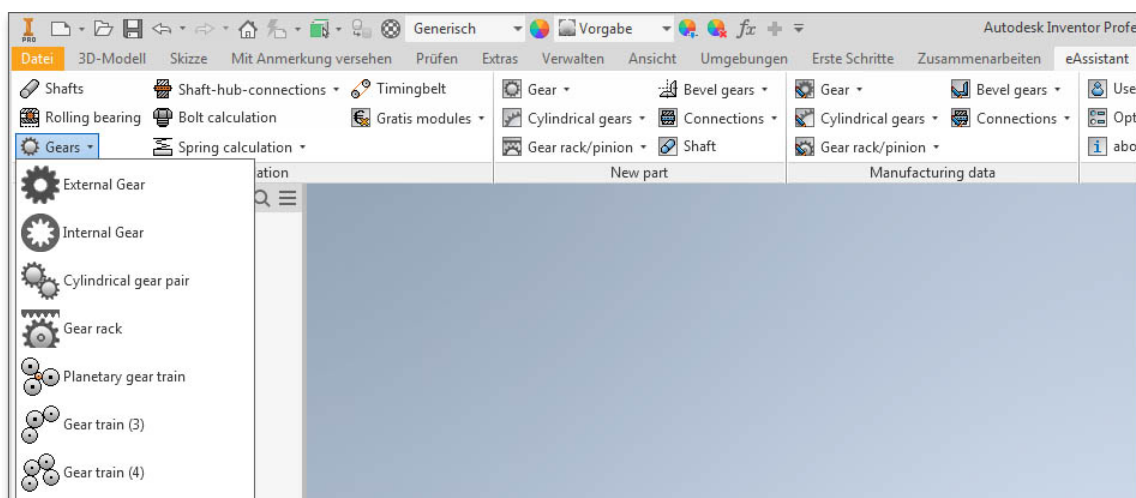

Figure 1.2: Start

## 1.3 Program Scope

Currently, the following features can be created in Autodesk Inventor based on the calculated eAssistant/TBK data:

- External and internal cylindrical and helical gears
- Rack/pinion gear pairs
- Straight, helical and spiral bevel gears
- Serrated shafts, splined shaft connections (shaft/hub)
- Solid and hollow shafts with an unlimited number of cylindrical and conical shaft segments
- Involute splines (shaft/hub)

as well:

- Saving of calculation data in the 3D model
- Placing manufacturing data of cylindrical gears, bevel gears and involute splines on the manufacturing drawing
- Cylindrical gears and involute splines can be created directly on an existing part.
- Bidirectional connection between eAssistant/TBK and Autodesk Inventor (shaft, gear, involute spline profile as single design component)
- Accuracy/point distance for the tooth form can be defined in the options menu.
- Tooth flanks as splines or alternatively as arcs for cylindrical gears and involute tooth profiles possible

## 1.4 Menu

### 1.4.1 Calculation

Once the CAD plugin is started, all eAssistant/TBK calculation modules can be opened directly through the tab 'Calculation' in Autodesk Inventor.

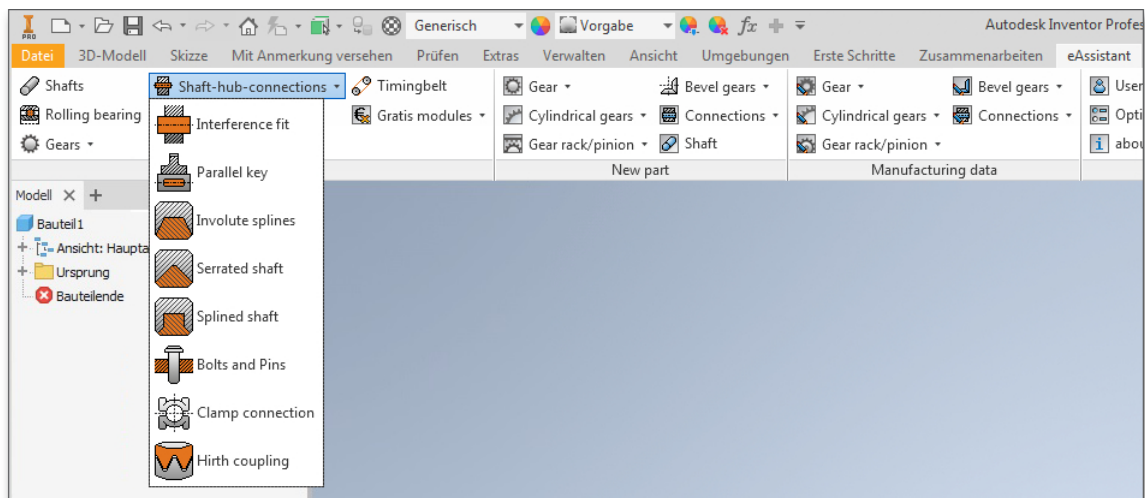

Figure 1.3: Calculation

**Note on eAssistant:** Please note that you need an eAssistant username and password to start the calculation modules through the 'Calculation' menu (see 'Settings/Help'). Only the free-of-charge modules can be used without the eAssistant access data.

### 1.4.2 New Part

Based on the eAssistant/TBK calculation, the parts can be created directly in Autodesk Inventor by clicking the tab 'New part'.

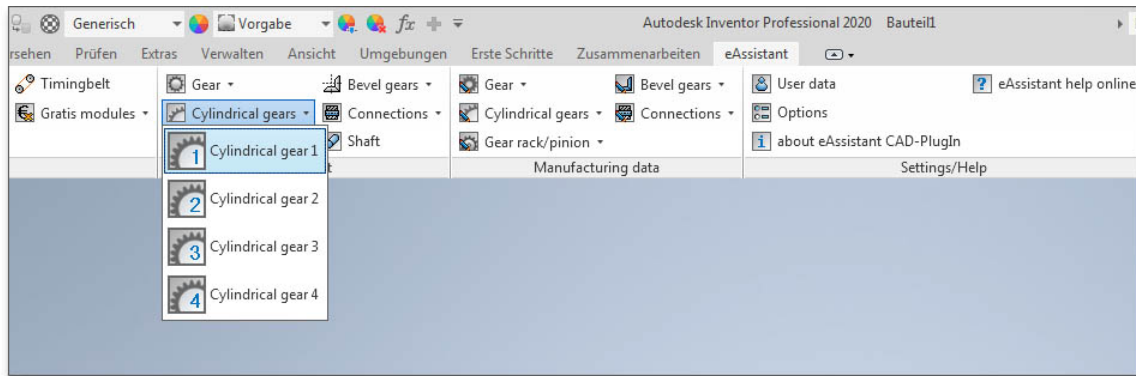

Figure 1.4: New part

Complete a calculation using the eAssistant/TBK. Click on the button 'CAD ⇒ Autodesk Inventor export' in the top menu bar of the eAssistant/TBK. Confirm the message 'Data for CAD was written successfully.' with the button 'OK'.

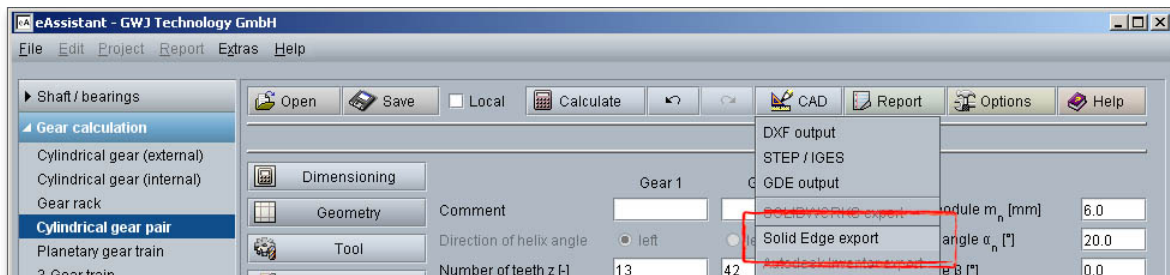

Figure 1.5: Autodesk Inventor Export

**Please Note:** During the generation of involute gearings (cylindrical gears, single cylindrical gears, gear racks, involute splines), **we recommend** to select the mean tooth thickness allowances and the mean tip diameter allowances. The CAD model is then created with these allowances. You can modify the allowances by opening the mask 'Tooth form' in the respective gear modules.

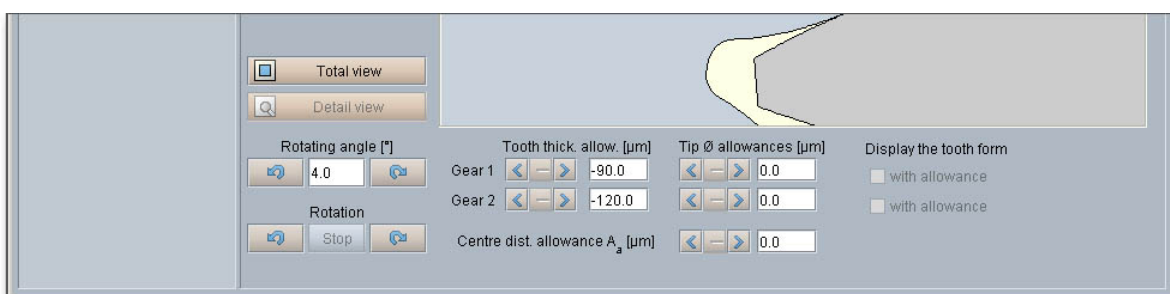

Figure 1.6: Mean tooth thickness and tip diameter allowances

Then click the menu tab 'New part' in the CAD plugin and select the corresponding element. Now the 3D model is created.

### 1.4.3 User Data (applies only for eAssistant)

Click the button 'User data' on the tab 'Settings/Help' to enter your eAssistant username and your password. You need an account to use all eAssistant calculation modules.

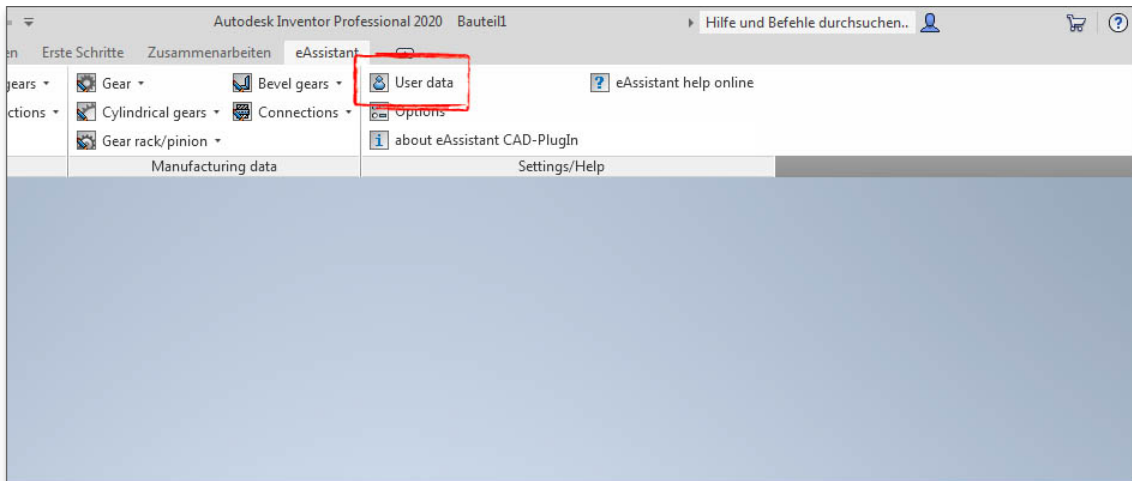

Figure 1.7: User data

In case you do not have an eAssistant account, please visit our web site [www.eAssistant.eu](http://www.eAssistant.eu) to register for a free test account. Click on the button Request access data to get to the eAssistant web site as well. The account provides a time credit of five hours to test the eAssistant without any charges or obligation. Are the five hours expired, the test account is deactivated automatically. If you want continue to use the eAssistant, you need to purchase an account. Decide between hour packages or flat rates.

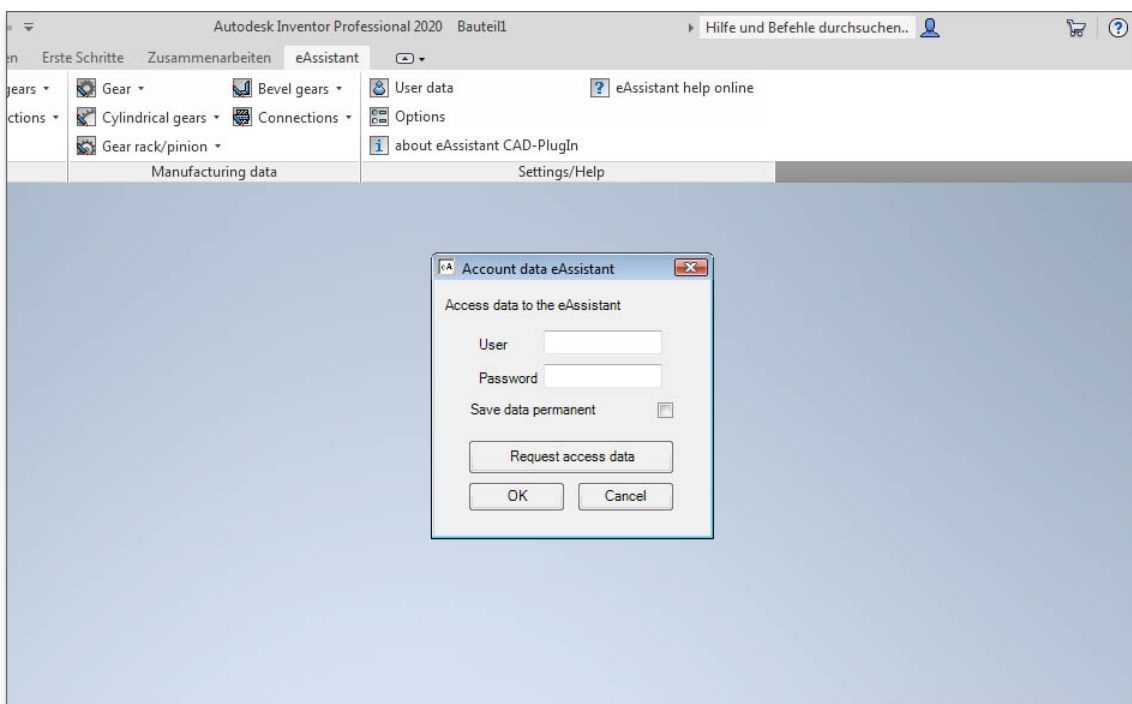

Figure 1.8: Access data

As soon as you entered your username and password into the window, you can start all eAssistant calculation modules directly through the tab 'Calculation' without logging in again. The eAssistant and Autodesk Inventor will be connected automatically.

**Please Note:** Activate the option 'Save data permanent' to save your username and password and to open all calculation modules immediately without entering username and password again.

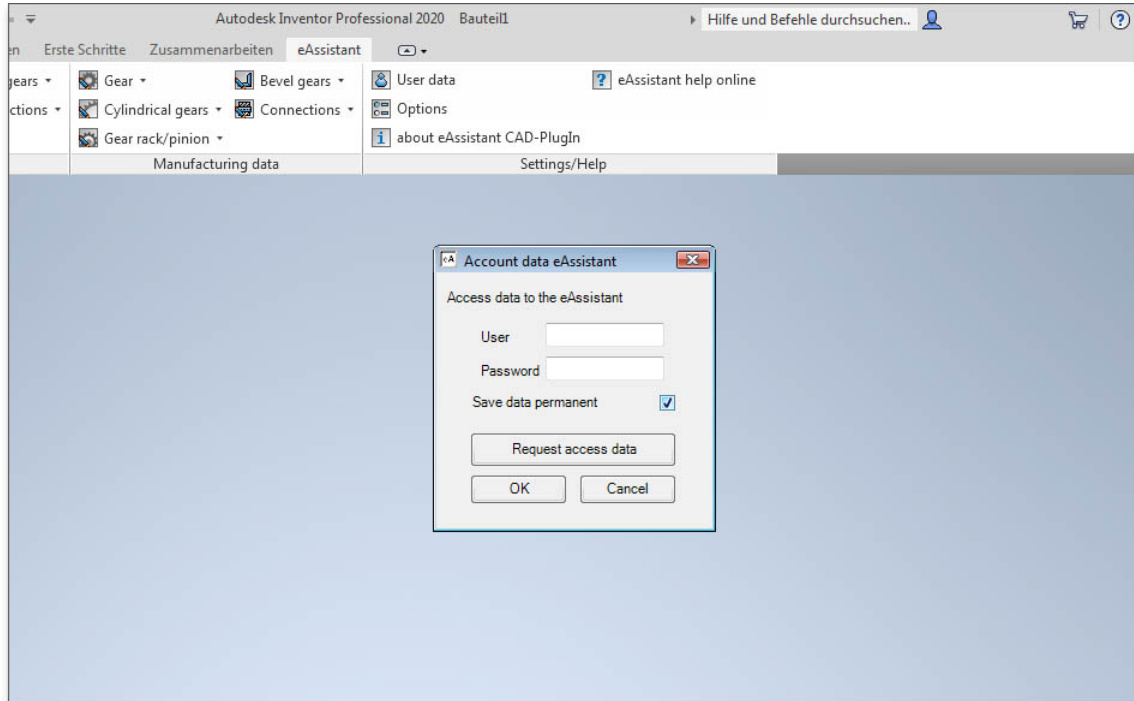

Figure 1.9: Save access data

#### 1.4.4 Options

Click the menu item 'Options' to adjust different settings for cylindrical and bevel gears. Select spline or arcs (tangential) to connect the points.

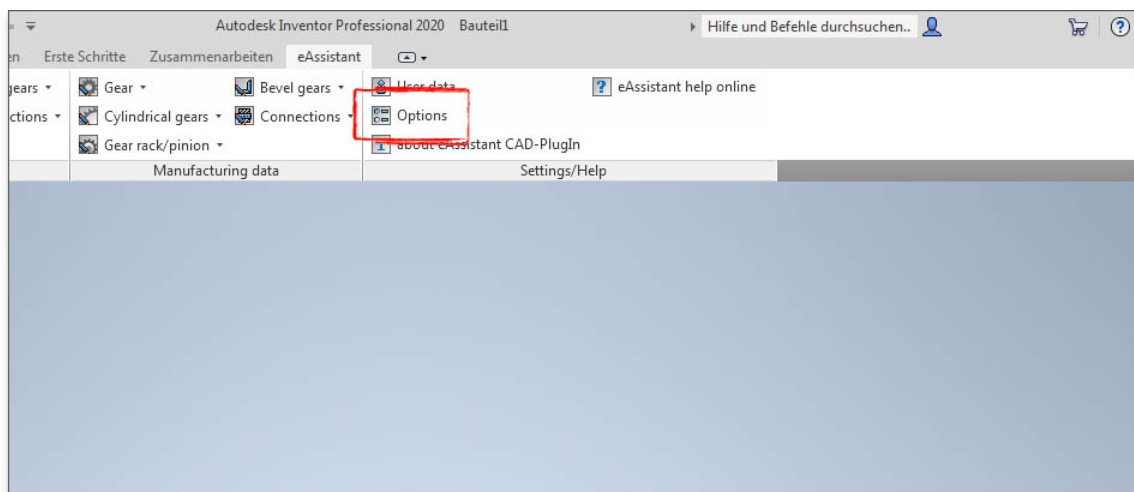

Figure 1.10: Options

You can, for example, define the distance between the points (accuracy) or the number of teeth to be generated. Just activate the checkbox and enter the appropriate number of teeth.

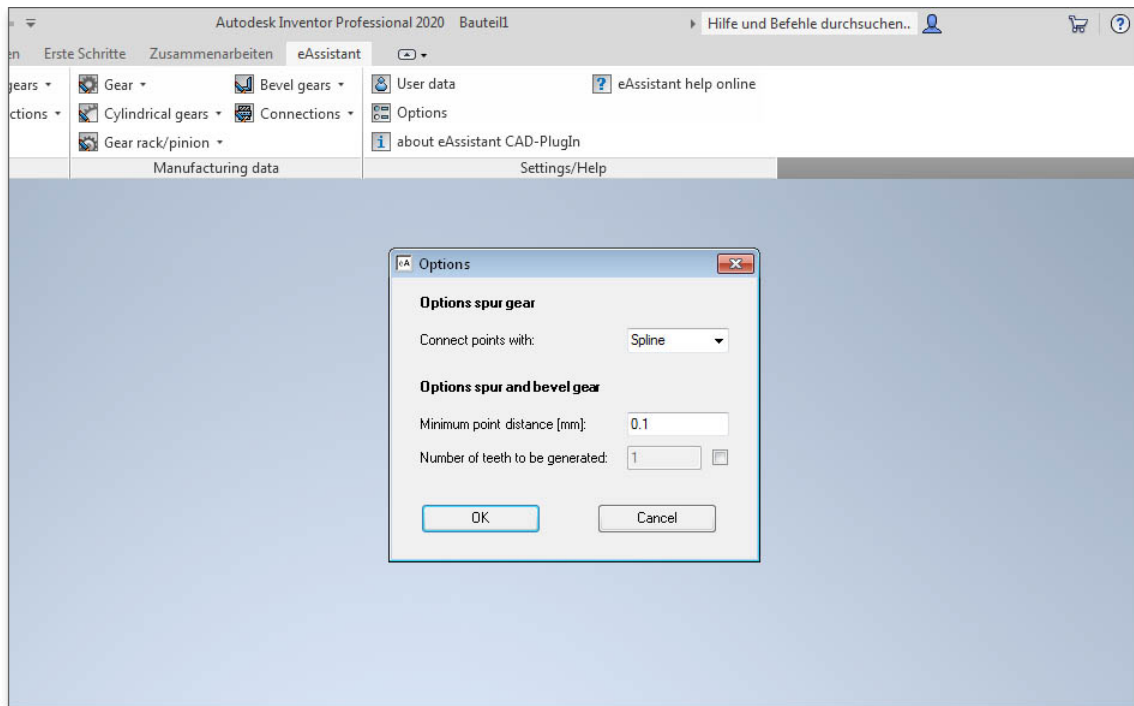

Figure 1.11: Accuracies

### 1.4.5 Help

Click on the menu item 'eAssistant (TBK) help online' to open the eAssistant/TBK manual where you can find additional information on the eAssistant/TBK.

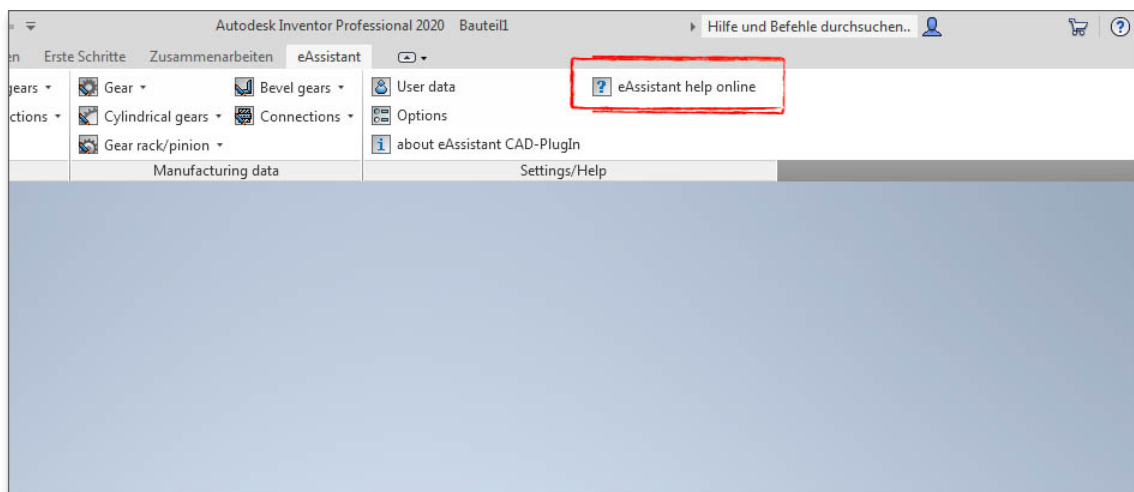

Figure 1.12: Help

## 1.5 Create a Shaft

Based on the eAssistant/TBK calculation, shafts with an unlimited number of cylindrical and conical segments can be created as a 3D part. Click on the tab 'Calculation ⇒ Shaft' to start the eAssistant/TBK module. Then make a shaft calculation. Click on the button 'CAD ⇒ Autodesk Inventor export' in the eAssistant/TBK module.

Create the shaft in Autodesk Inventor by clicking on the menu item 'New part ⇒ Shaft'.

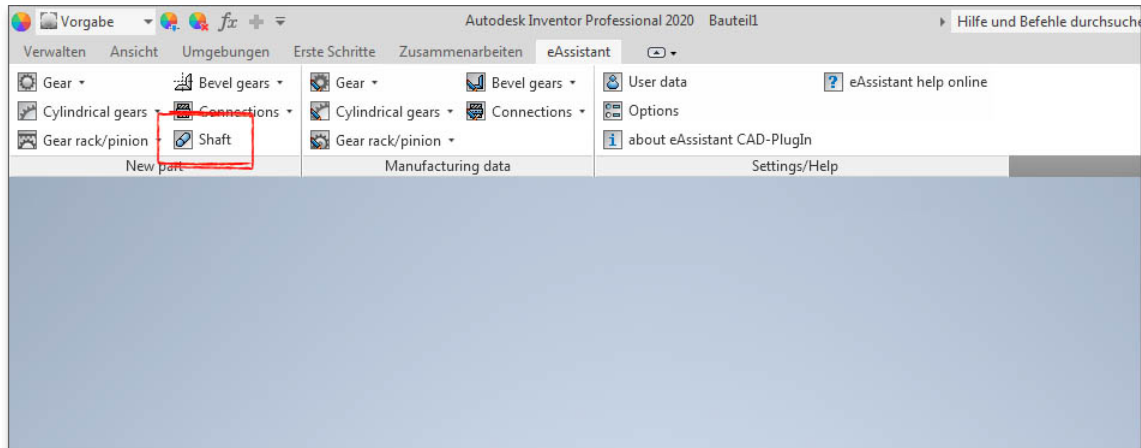

Figure 1.13: Create a shaft

**Please Note:** You can also create a 2D sketch of a shaft in Autodesk Inventor and then import it to eAssistant/TBK. Please see Section 1.12 for more information.

## 1.6 Create a Cylindrical Gear

Click on the menu item 'Calculation ⇒ Gears ⇒ Cylindrical gear pair' in order to start the eAssistant/TBK calculation module. Then make a calculation. Click on the button 'CAD ⇒ Autodesk Inventor' export in the eAssistant/TBK module.

Click on the menu item 'New part ⇒ Cylindrical gears ⇒ Cylindrical gear 1' or cylindrical gear 2, 3, 4 to create the cylindrical gear in Autodesk Inventor.

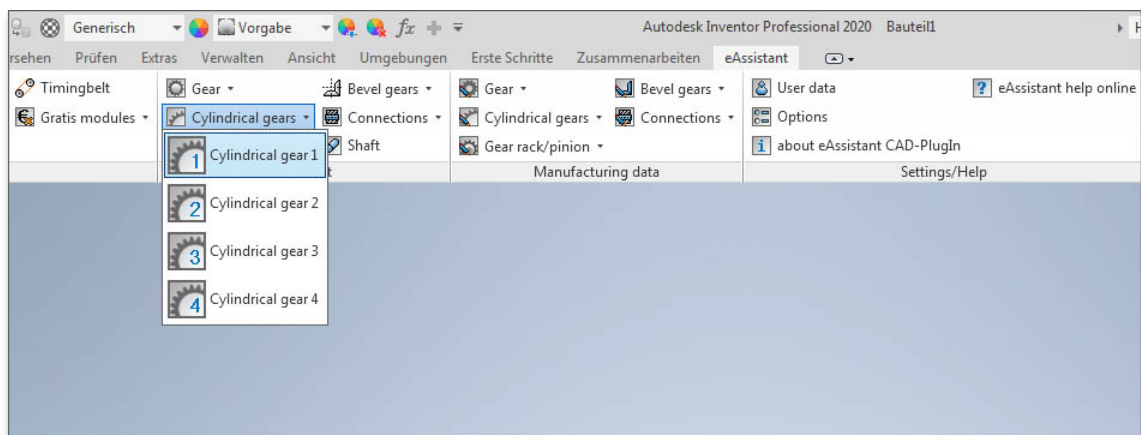

Figure 1.14: Create a cylindrical gear

## 1.7 Create a Gearing on an Existing Part

The eAssistant/TBK plugin provides a simple way to create a gearing directly on an existing part (pinion shaft).

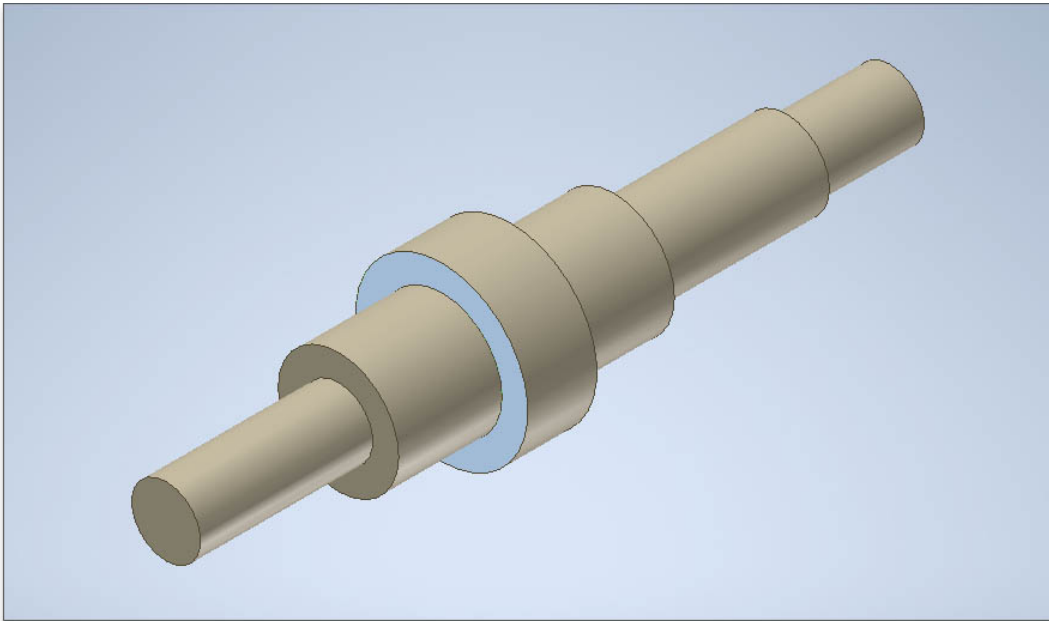

Figure 1.15: Existing part

Make a gear calculation in the eAssistant/TBK. Click on the button 'CAD  $\Rightarrow$  Autodesk Inventor export'. Select the front face where you want to place the gearing. The face will then be highlighted. Select the menu item 'New part  $\Rightarrow$  Cylindrical gears  $\Rightarrow$  Cylindrical gear 1' to add the gearing to the existing part.

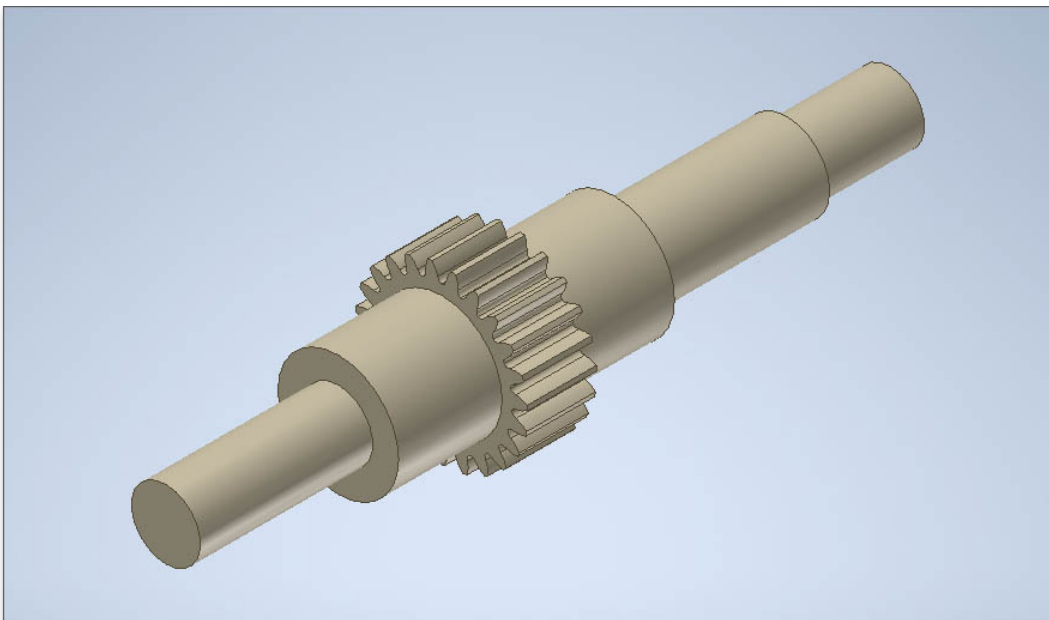

Figure 1.16: Gearing on existing part

When the dialog window for the 'Runout configuration' appears, confirm with the 'OK' button. Please note that the tip circle diameter of the cylindrical gear and the diameter of the selected shaft segment must have the same size!

## 1.8 Add Manufacturing Data to Engineering Drawing

With just one click, the design table with all manufacturing details can be placed on the manufacturing drawing. Open a drawing in Autodesk Inventor. Select the menu item 'Manufacturing data ⇒ Cylindrical gears ⇒ Cylindrical gear 1' to create the table.

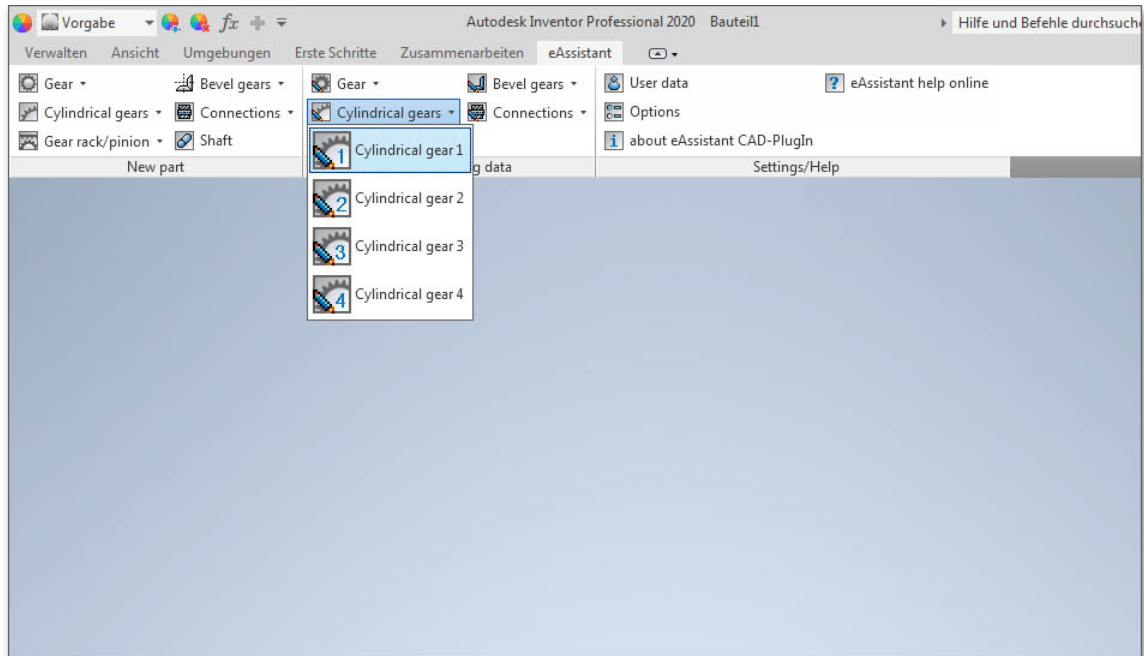

Figure 1.17: Add manufacturing data to the drawing

After installation of the CAD plugin, the file 'Manufacturingdata.xml' appears in the program directory. When calling the manufacturing data via the CAD plugin, a new folder is created in the Windows directory C:\User\[Username]\AppData\Roaming. Various templates (for example 'ManufacturingdataBG.xml') for the design tables are saved in this folder and only these XML files are used to configure the table. Based on these files, the design table can be modified to your preferences.

Cylindrical gears, bevel gears and involute splines get a template as soon as you call the manufacturing data. For bevel gears, a distinction is made between straight/helical bevel gears and spiral bevel gears. The appearance and size of that table are both individually configurable.

Open the XML file with a text editor and change the corresponding rows, for example from 'visible=true' into 'visible=false' to show or hide specific table rows. Sort rows with cut and paste, mix numeric values and text or add an image.

Save the XML file and place it to the manufacturing drawing.

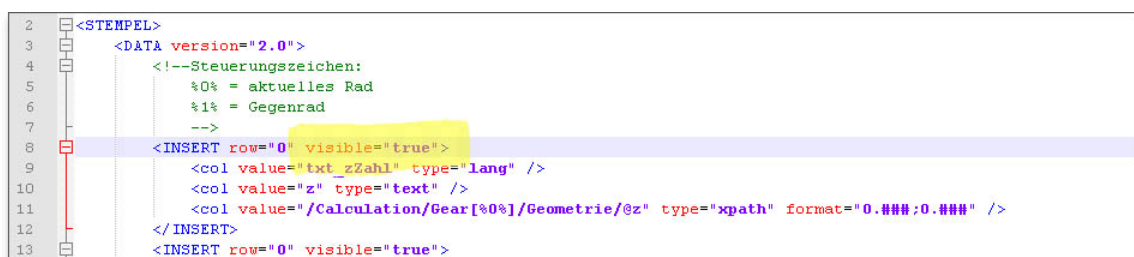

Figure 1.18: XML file

In case you need more extensive customizations (font size, column width, etc.) of the table, please contact our support team.

Basically the table with manufacturing data can be adapted to your individual requirements. Whether any number of columns or additional information and illustrations, such as a logo, the formatting options are very diverse and flexible. Here is an example of how the manufacturing table could look like:

Zahnwelle		
Profilbezeichnung / Profile description		DIN 5480 – W 40 x 2,0 x 18 x 9e
Bezugs- $\phi$ / Basis diameter	d B	40,0
Teilkreis- $\phi$ / Reference diameter	d	36,0
Modul / Modul	m	2,0
Eingriffswinkel / Pressure angle	alpha n	30 °
Zähnezahl / Number of teeth	z	18
Profilverschiebungsfaktor / Addendum modification factor	x'	0,45
Profilverschiebung / Addendum modification	x'm	0,9
Werkzeugkopfhöhenfaktor / Addendum coefficient	h ap0'	0,6
Fusskreis- $\phi$ / Root diameter	d f	35,298 –0,078
Kopfkreis- $\phi$ / Tip diameter	d a	39,6
Toleranzfeld / Tolerance zone		9e
Prüfmaß / Check dimension MdR		
Rollen- $\phi$ / Roll- $\phi$	dm	4,50
Nennmaß / Nominal dimension	MdR nenn	45,137
Größtmaß / Max. dimension	MdR max	45,057
Mittelmaß / Mean dimension	MdR mittel	45,026
Kleinstmaß / Min. dimension	MdR min	44,996
Zahnweite Wk über 4 Zähne gemessen / Width of the teeth Wk measuring over 4 teeth		
Nennmaß / Nominal dimension	WK nenn	21,621
Größtmaß / Max. dimension	WK max	21,57
Mittelmaß / Mean dimension	WK mittel	21,550
Kleinstmaß / Min. dimension	WK min	21,531

Figure 1.19: Table with manufacturing data

### 1.8.1 Create User-defined Templates

You can create your own templates for the manufacturing data, which can then be conveniently selected from a listbox as soon as you want to place the manufacturing data on the drawing. You can create a completely new template or use an existing template (for example, 'Manufacturingdata.xml') as a basis and add entries.

**Please Note:** When creating the user-defined template, this new template must be located in the C:\User\[Username]\AppData\Roaming\eAssistant directory.

Open the XML file in a text editor, change the document according to your needs. Give the file a new name. In the following example, the file is named as 'ManufacturingdataNewTemplate'. Save the file again as XML file and close it.

Now open the file 'eAssistantXML.xml' from the directory C:\User\[Username]\AppData\Roaming\eAssistant. Here the file you saved before ('ManufacturingdataNewTemplate') must be included.

The example is manufacturing data for cylindrical gears, so the new template is created under 'Gear'. Under 'Filename' you enter 'ManufacturingdataNewTemplate', under 'langKey' you define the name to be displayed in the listbox ('This is a new template').

```

2 <gwj type="config">
3 <mainParameters domain="http://eassistant.mmm.com" register="http://www.eassistant.de/preise/testzugang/ind
4 <language german="de" english="en" french="fr" spanish="es" active="german" />
5 <calculation fitcalc="AppletFitCalc.html" hardness="AppletHardness.html" shaftdim="AppletShaftDim.html" shaf
6 <user username="" password="" />
7 <tbk path="" />
8 <manufacturingdata showDialog="True">
9 <bevelgear>
10 <template filename="ManufacturingdataB60" langKey="txt_BevelgearStandard" bevelgearID="0" standard="True
11 <template filename="ManufacturingdataB61" langKey="txt_BevelgearStandard" bevelgearID="1" standard="True
12 </bevelgear>
13 <gear>
14 <template filename="Manufacturingdata" langKey="txt_GearStandard" standard="True" />
15 <template filename="ManufacturingdataNewTemplate" langKey="This is a new template" standard="False" />
16 </gear>
17 <gearrack>
18 <template filename="ManufacturingdataZahnstangeRitzel" langKey="txt_GearrackpinionStandard" pinion="True
19 <template filename="ManufacturingdataZahnstange" langKey="txt_GearrackStandard" pinion="False" standard=
20 </gearrack>
21 <geartrain>
22 <template filename="ManufacturingdataGearTrain" langKey="txt_GeartrainStandard" standard="True" />
23 </geartrain>
24 <hirth>
25 <template filename="ManufacturingdataHirth" langKey="txt_HirthStandard" standard="True" />
26 </hirth>
27 <involutesplines>
28 <template filename="ManufacturingdataZW" langKey="txt_InvolutesplinesStandard" standard="True" />
29 </involutesplines>
30 <singlegear>
31 <template filename="ManufacturingdataEinzelrad" langKey="txt_SinglegearStandard" standard="True" />
32 </singlegear>

```

Figure 1.20: New template

Restart Autodesk Inventor. If you now place the manufacturing data of a cylindrical gear on the drawing, first the listbox is displayed. Here you can then select the corresponding template. If you activate 'Do not display this dialog again', the standard file will be opened automatically.

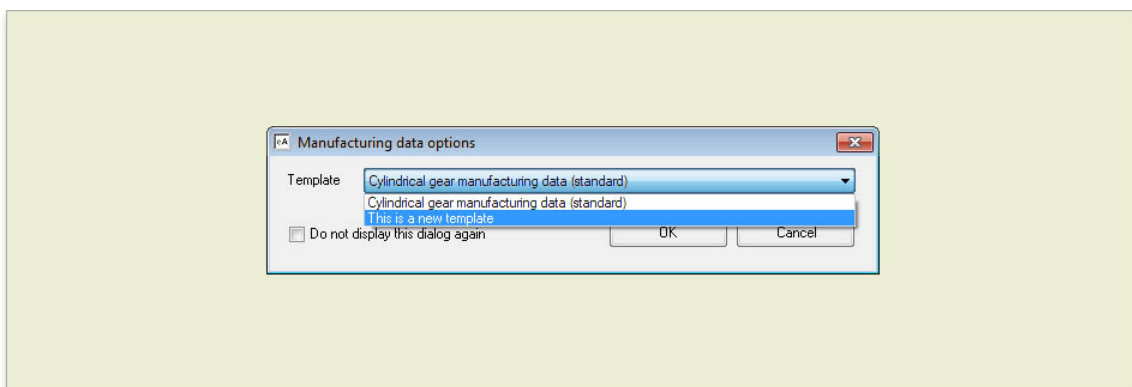

Figure 1.21: Selection of the new template

**Please Note:** If you delete the folder 'eAssistant' in the user directory, the templates (XML files) will be deleted, too. To avoid this, please create a backup of the folder.

In case the path C:\User\[Username]\AppData\Roaming is not displayed, you need to adjust the folder options. Open the folder options by clicking 'Start ⇒ Control panel ⇒ Folder options'.

Click the View tab. Select 'Show hidden files, folders, and drives' under 'Hidden files and folders'. Click 'OK' to save the new setting.

**Please note:** The adjustments to the XML files are not taken over when updating the CAD plugin. All changes due to updates have to be updated manually.

## 1.9 Open a Calculation of an Active Part

The calculation information is saved in the 3D model. The calculation, which belongs to the 3D model, can be opened at any time throughout the entire design phase. If a component contains several different calculation elements, it is possible to open the corresponding calculations.

To start the calculation, which belongs to the opened 3D model, use the tab 'Calculation' and select the corresponding calculation module. The following dialog window appears.

Click the 'Yes' button and the eAssistant/TBK opens the calculation module with all calculation values. The following dialog window appears.

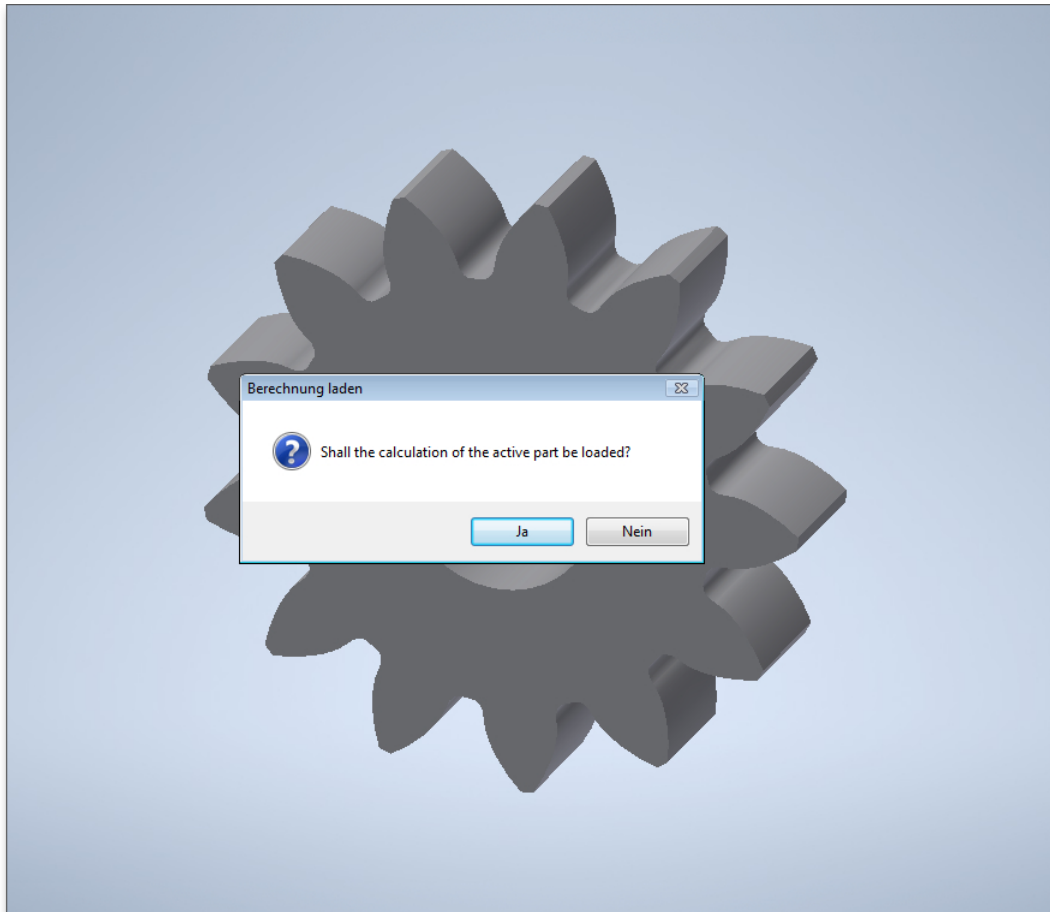

Figure 1.22: Open the calculation

Even if there are several different gear calculations in one 3D model, you can open every calculation file again. For the gear, for example, click on the feature tree on the left side in Autodesk Inventor to select the corresponding cutout. Click on the tab 'Calculation' and then click on the calculation module.

## 1.10 Add a Tool Runout to the 3D Model

For pinion shafts you can add a tool runout to the 3D model. For this purpose, you have to specify a cutter radius. Select the menu item 'Calculation ⇒ Gears ⇒ Cylindrical gear pair' and run a cylindrical gear calculation.

Click the button 'CAD ⇒ Autodesk Inventor export'. Choose a plane of the shaft in Autodesk Inventor and click the menu item 'New part ⇒ Cylindrical gears ⇒ Cylindrical gear 1'.

The dialog window is opened. Activate the option 'Yes' for 'Run-out at start' or 'Run-out at end'. Add a cutter radius and confirm with 'OK'.

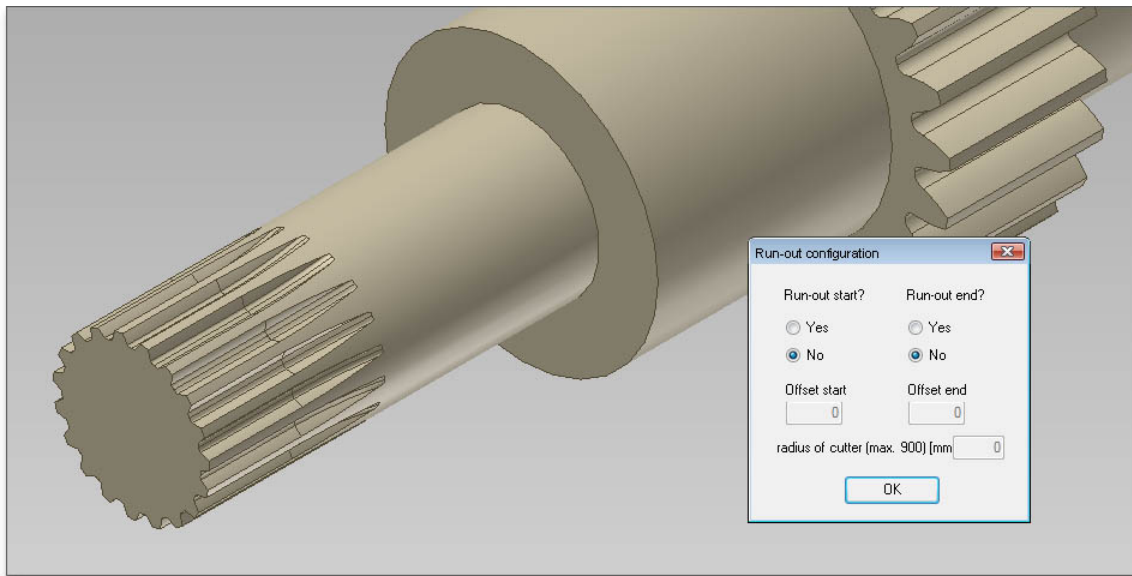

Figure 1.23: Runout

Now you can check if the tool runout collides with the following shaft segment, so that you can correct it. If necessary, you can add a straight element by using the option 'Offset'.

## 1.11 Bidirectional Connection between eAssistant/TBK and Autodesk Inventor

The attractiveness of the CAD plugin is additionally enhanced by the bidirectional connection between eAssistant/TBK and Autodesk Inventor. As changes are made to a calculation, the 3D model can be updated (shafts, cylindrical gear or involute spline profile/hub profile as single part).

Select the menu item 'Calculation ⇒ Gears ⇒ Cylindrical gear pair' and make a cylindrical gear calculation.

Click the button 'CAD ⇒ Autodesk Inventor export' to transfer the calculation values to Autodesk Inventor.

Click the Autodesk Inventor menu item 'New part ⇒ Cylindrical gears ⇒ Cylindrical gear 1' to create the cylindrical gear.

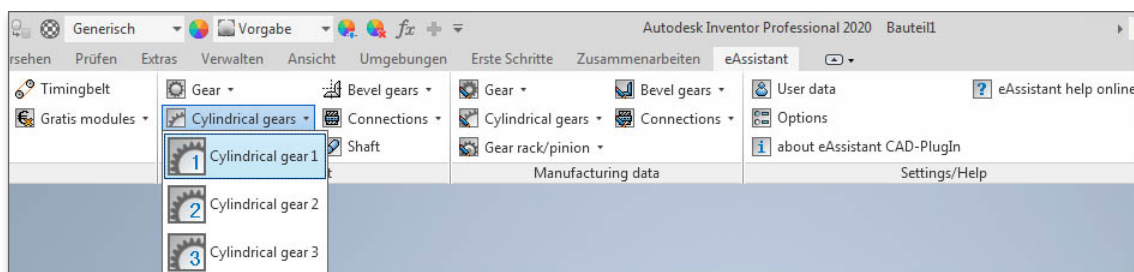

Figure 1.24: Create a gear

To make necessary changes on the CAD model, re-open the eAssistant/TBK module and modify the calculation. Because the calculation information is saved to the CAD model, you can start the eAssistant/TBK calculation by clicking 'Calculation ⇒ Gears ⇒ Cylindrical gear pair'.

Confirm the following message 'Shall the calculation of the active part be loaded?' with the button 'Yes' and the related calculation module starts. For example, you can add a hole to gear 1. Click on the button 'CAD ⇒ Autodesk Inventor export'.

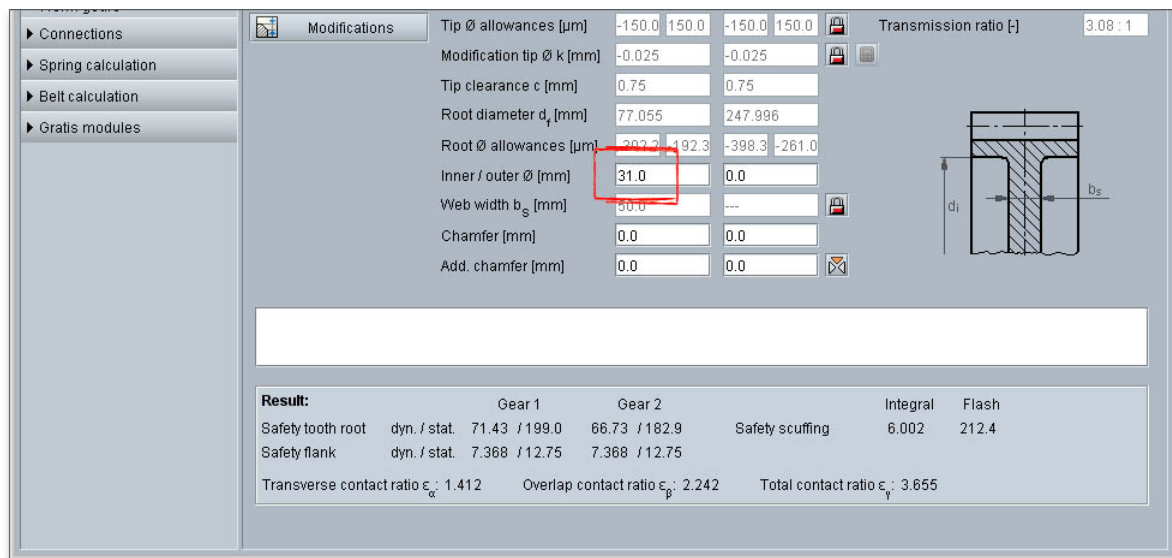

Figure 1.25: Add a hole

Select the cutout feature from the integrated Autodesk Inventor feature tree. The area between the teeth will then be highlighted.

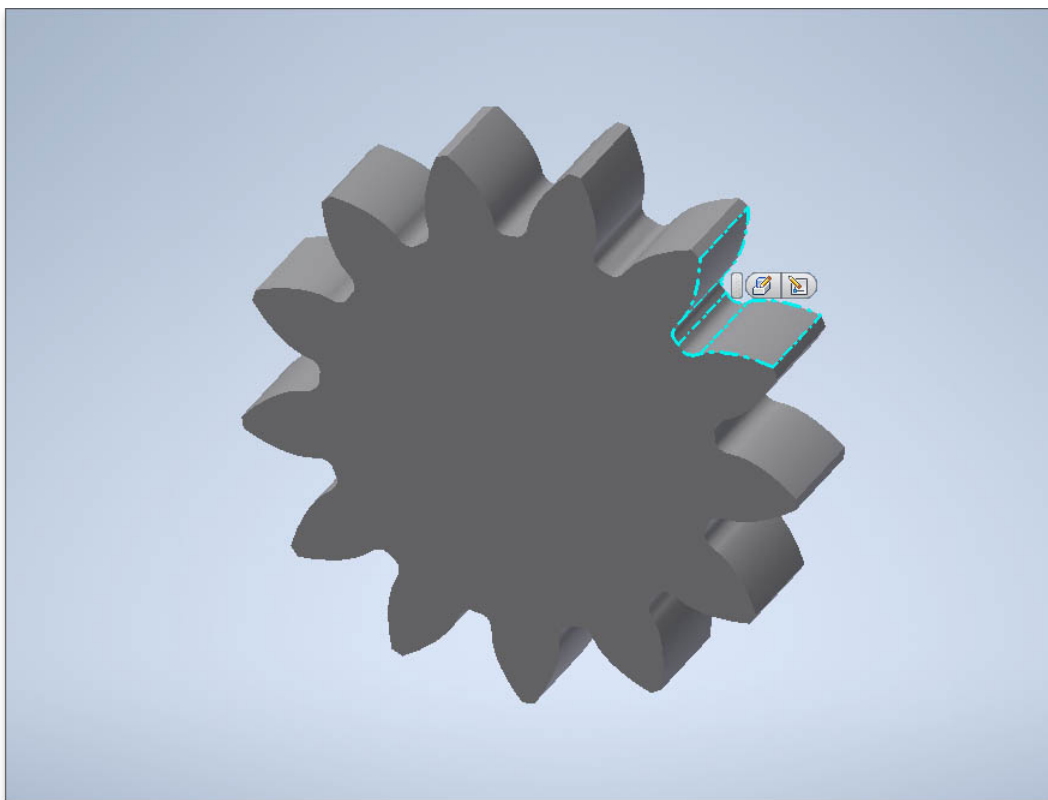

Figure 1.26: Select the area

Select 'New part ⇒ Cylindrical gears ⇒ Cylindrical gear 1' and the message 'Should the component be adjusted to the current calculation?' appears.

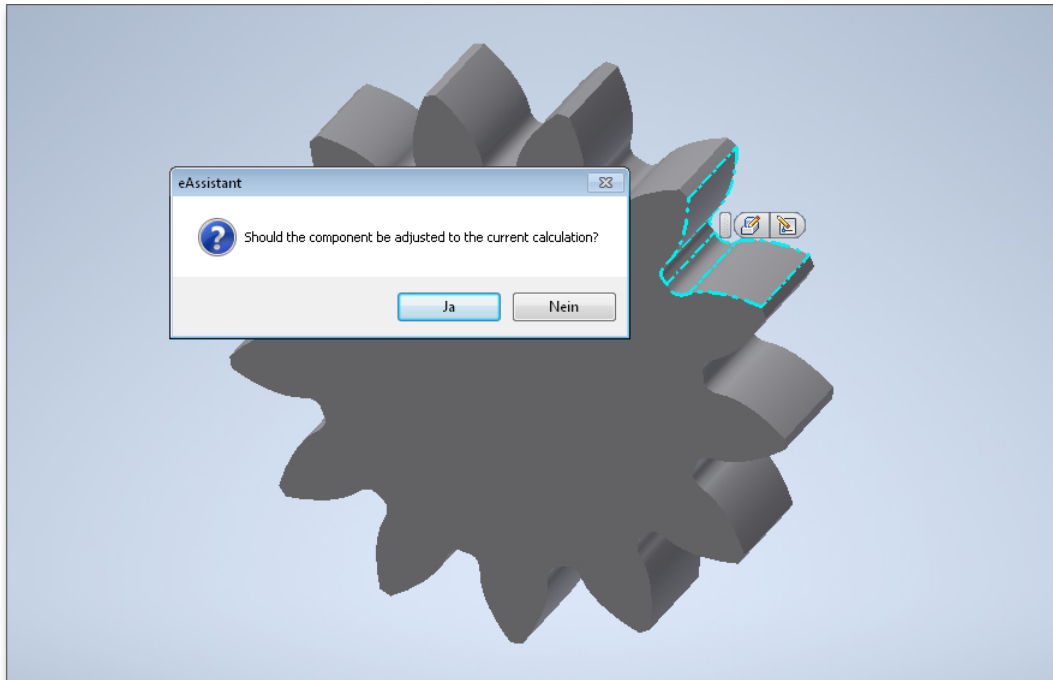

Figure 1.27: Adjust to the current calculation

Click the 'Yes' button and the CAD model is updated immediately and quickly adjusted to the current calculation.

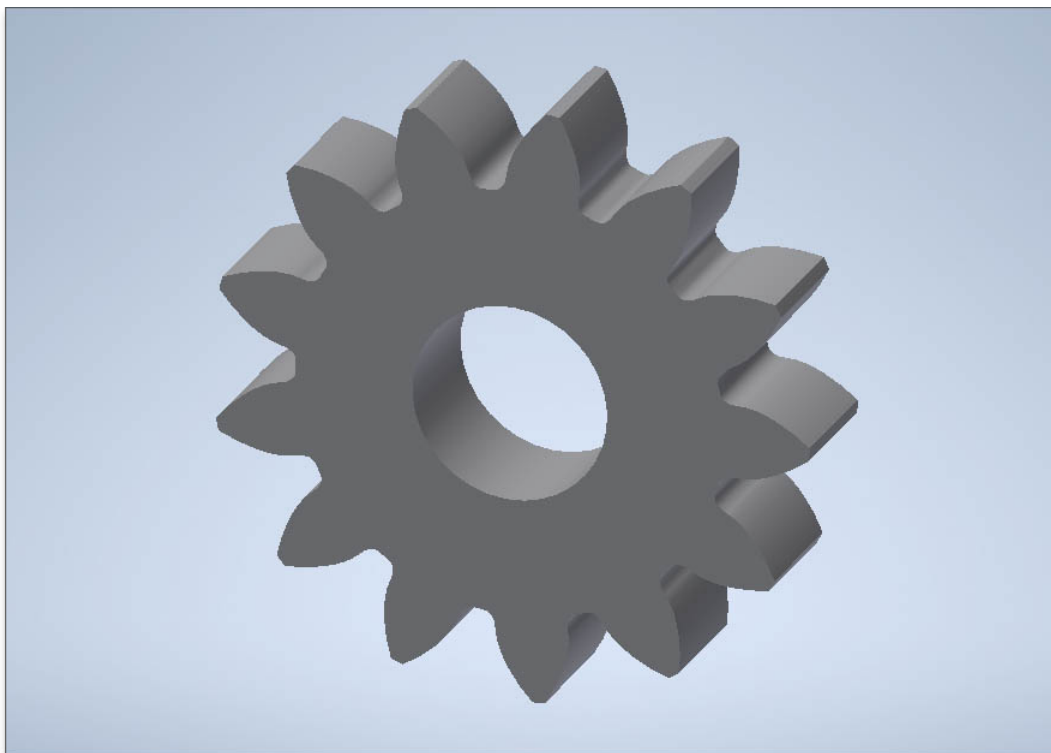

Figure 1.28: CAD model

## 1.12 Create a Shaft in Autodesk Inventor and Import it into eAssistant/TBK

You can create a shaft directly in Autodesk Inventor and then import it into eAssistant/TBK. Solid and hollow shafts with cylindrical and conical shaft segments are possible. To create a shaft as a revolved part, use the CAD's revolve features, the inner shaft geometry can be generated using the revolved cut feature.

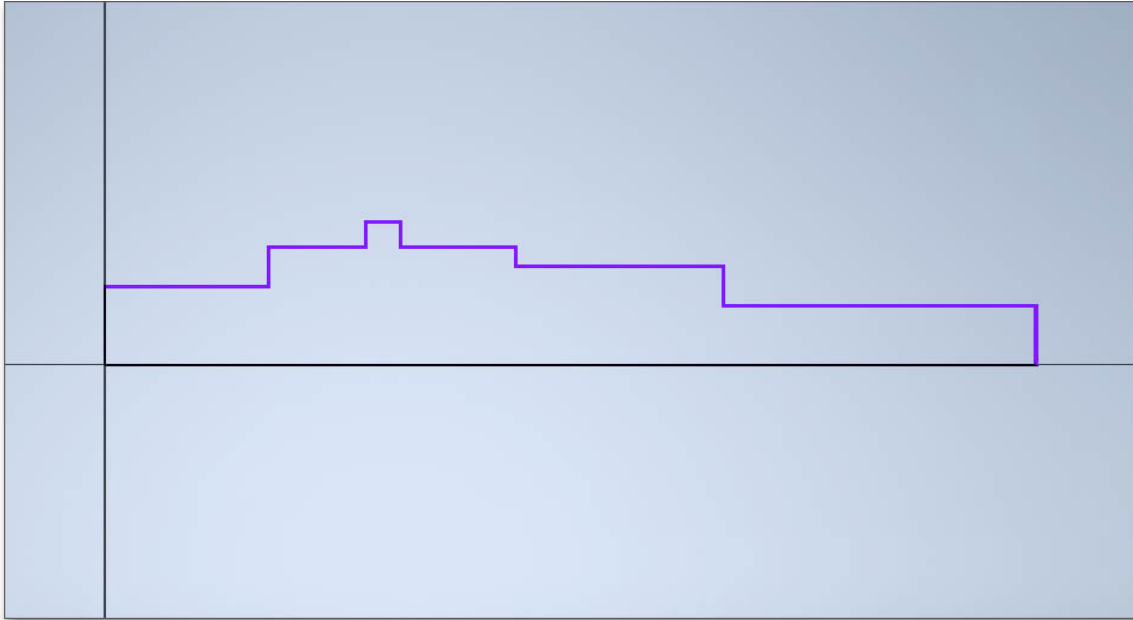

Figure 1.29: Shaft geometry

To create a shaft as a revolved part, use the Autodesk Inventor Revolved Features.

Select the corresponding feature(s) from the FeatureManager design tree and import the shaft into eAssistant/TBK by clicking the menu item 'Calculation ⇒ Shafts'.

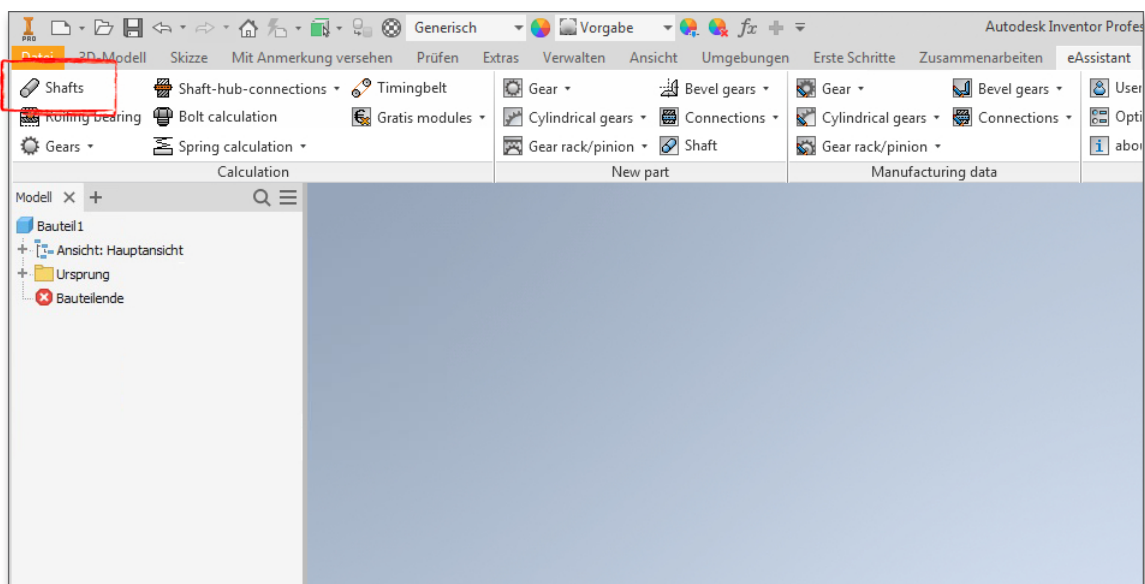

Figure 1.30: Calculation of the shaft

The eAssistant/TBK shaft module opens and the shaft is loaded into the calculation module.

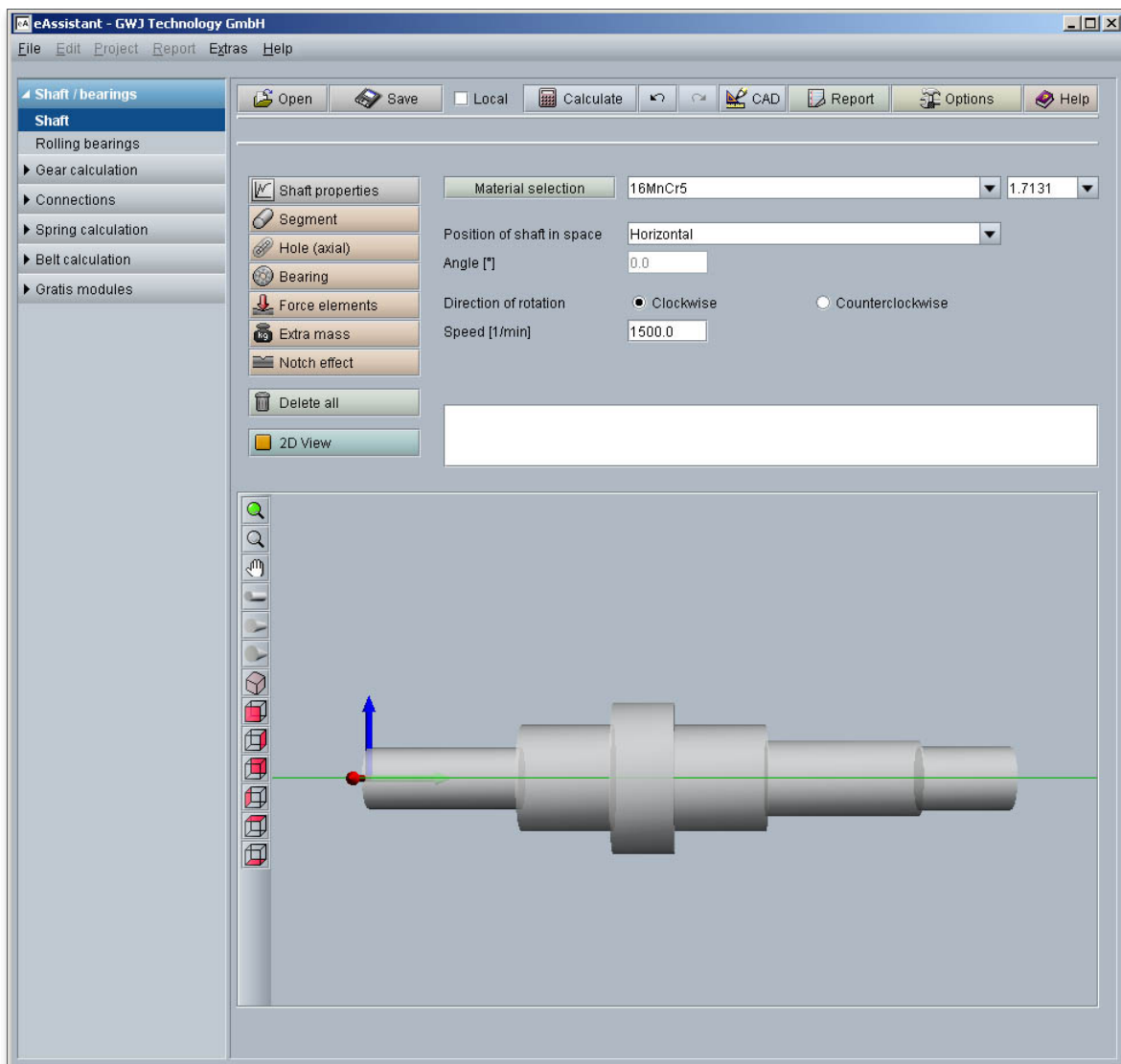

Figure 1.31: Shaft in eAssistant/TBK