

Calculation Example

Rolling Bearings According to DIN ISO 281

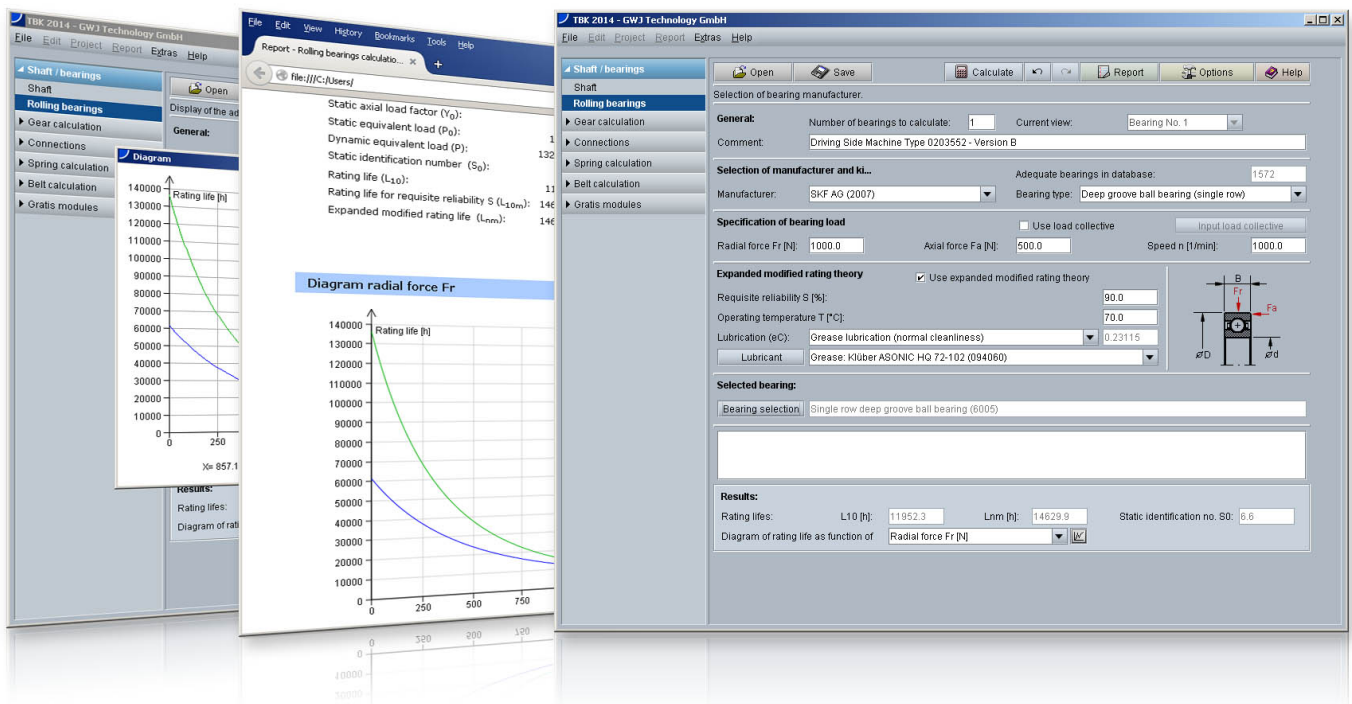

Release March 2025

Contents

0.1	Calculation Examples: Rolling Bearing According to DIN ISO 281	3
0.1.1	Start the Calculation Module	3
0.1.2	First Calculation Example	3
0.1.3	The Calculation	4
0.1.4	Calculation Results	6
0.1.5	Documentation: Calculation Report	8
0.1.6	Save the Calculation	9
0.1.7	Second Calculation Example	10
0.1.8	The Calculation	11
0.1.9	Calculation Results	13
0.1.10	Documentation: Calculation Report	15
0.1.11	Save the Calculation	16

0.1 Calculation Examples: Rolling Bearing According to DIN ISO 281

0.1.1 Start the Calculation Module

To start the calculation module for rolling bearings, please click the menu item 'Shaft/Bearings' on the left side and then select 'Rolling bearings'.

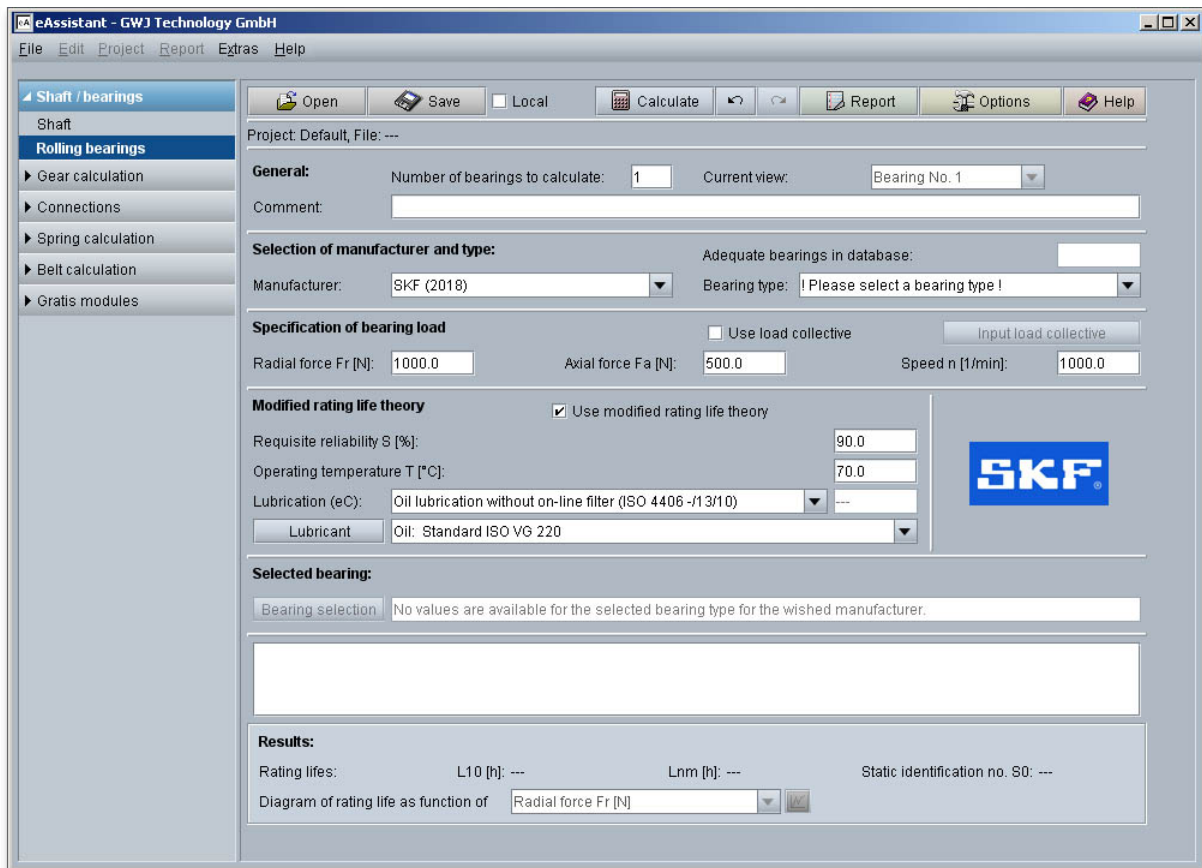

Figure 1: Start the calculation module

0.1.2 First Calculation Example

Bearing for a Rope Sheave of a Pulley Block

The wrap angle for rope sheaves of pulley blocks is 180° . Therefore, the load on the bearing is twice the rope pull. The axial forces and the resulting moments are low. When the diagonal pull is 5° , then the axial forces have to be considered for the calculation of the rating life. Adequate bearing spread for load accommodation is achieved by mounting either two bearings or one double-row bearing. In the following example the rating life and modified rating life are to be calculated. We have taken this example from: J. Braendlein: Die Waelzlagpraxis: Handbuch zur Berechnung und Gestaltung von Waelzlagern (1995, p. 466-470).

Please enter the following input values:

Bearing load = 65 kN

Type of bearing = Tapered roller bearing (single row)

Speed $n = 30 \text{ min}^{-1}$

Built-in bearing = Tapered roller bearing (100 x 150 x 67)

For-life lubrication = Grease with EP-additive

Illustration of a rope sheave of a pulley block including the tapered roller bearing. (The following figure: J. Braendlein: Die Waelzgerpraxis, p. 467).

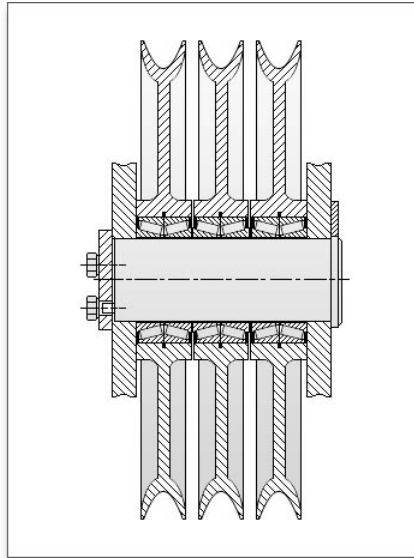

Figure 2: Rope sheave of a pulley block

0.1.3 The Calculation

Define Number of Bearings

In this example we would like to calculate one bearing of a tapered roller bearing pair. When you open the calculation module, usually one bearing is shown. So it is not necessary to change the number of the bearings. You can enter a description into the comment field, for example 'Bearing of the rope sheave'.

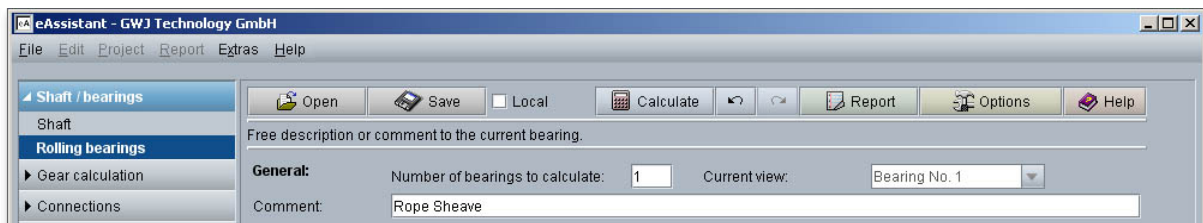

Figure 3: Number of bearings

Select Manufacturer and Bearing Type

The extensive bearing database provides over 20,000 bearings from different manufacturers. Select the bearing manufacturer SKF 2007 from the listbox. Next, choose the bearing type Tapered roller bearing (single row).



Figure 4: Select the manufacturer and bearing type

Specification of Bearing Load

Enter the values for the bearing load now. Please keep in mind that the values will be entered in kN. Clicking on the label allows you to change the unit.

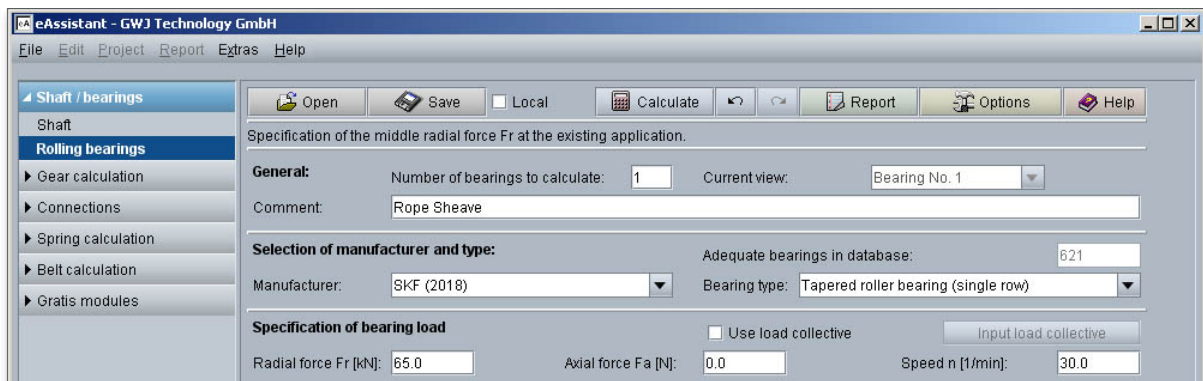

Figure 5: Values for the bearing load in kN

Bearing Selection

Click on the button 'Bearing selection' to open the bearing database.



Figure 6: Button 'Bearing selection'

There are 578 bearings in the database right now. Search filters have been developed to assist in searching this extensive amount of bearings and to quickly find the bearing you are looking for. You can filter the bearing types by the inner and outer diameter so that you can only see bearing types with this particular diameter. Enter the inner and outer diameter and click the button 'Search'.

Inner diameter of bearing = 100 mm
Outer diameter of bearing = 150 mm

Select the bearing 32020 X* and confirm with the button 'OK'.

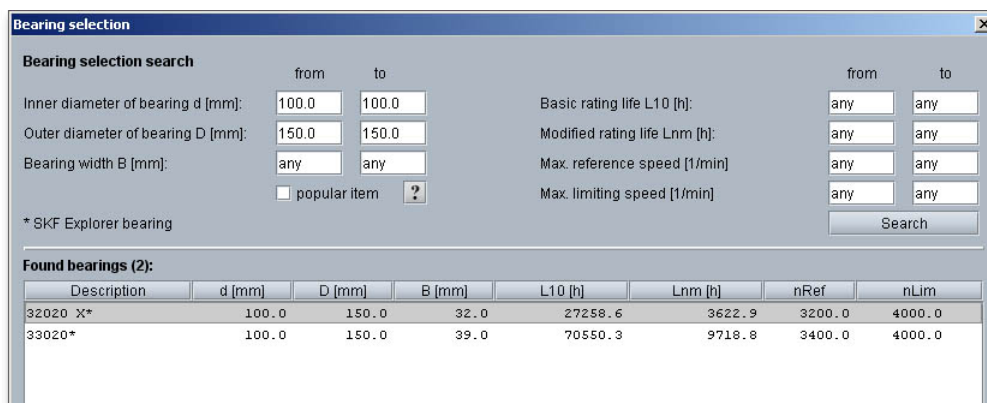

Figure 7: Found bearings

0.1.4 Calculation Results

Rating Life

All results will be calculated during every input and will be displayed in the result panel. A recalculation occurs after every data input. Any changes that are made to the user interface take effect immediately. First, you get the result for the rating life as well as the static identification number.

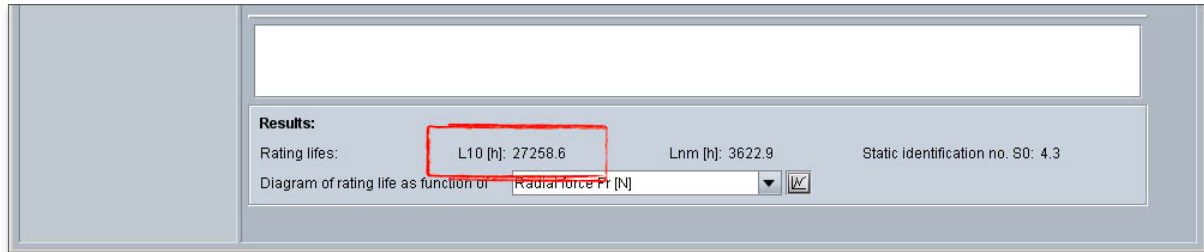

Figure 8: Result for the rating life

The result of the rating life is $L_{10} = 27,258.6$ h

For rope sheaves, a rating life from 5,000 to 20,000 hours is required. The bearing is sufficiently dimensioned. You will find a note in the message window but you can ignore this message. When the pair is fitted together, then the correct axial clearance and the necessary axial force for the tapered roller bearing occur.

Modified Rating Life Theory

After you get the result for the rating life, please have a look at the modified rating life theory L_{nm} regarding the operating conditions (lubrication, clearance). The option 'Use modified rating life theory' is activated by default.

Now you can define the requisite reliability and the cleanness as well as a lubricant. Please select the grease Klueber Kluebersynth BMQ 72-162 (094073). Select this lubricant directly from the listbox. If you need detailed information, please click on the button 'Lubricant'.

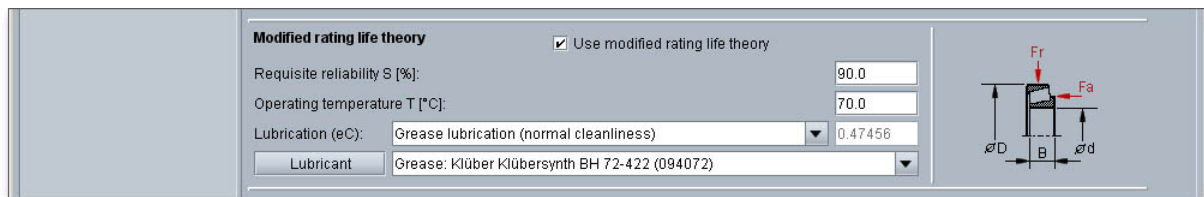

Figure 9: Modified rating life theory

Clicking the button 'Lubricant' opens the lubricant database. Here you can see that the grease contains active EP additive.

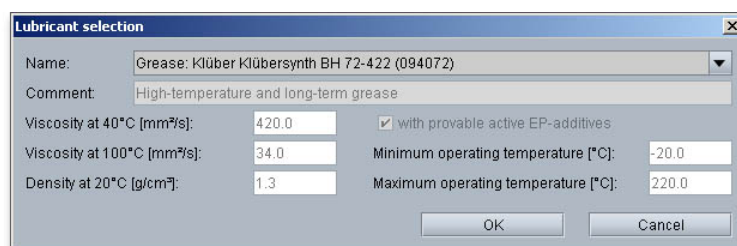

Figure 10: Lubricant database

Next, you have to estimate the influence of possible impurities by using the cleanliness factor. Actually, it is assumed that the 'highest cleanliness' is used for sealed and greased bearings (for-life-lubrication). But during the entire operating time, a certain wear of the seals could occur which can let light impurities into the bearing. In this case you can assume light impurities. Therefore, choose 'Light impurities' from the listbox.

Now you get immediately the result for the modified rating life.

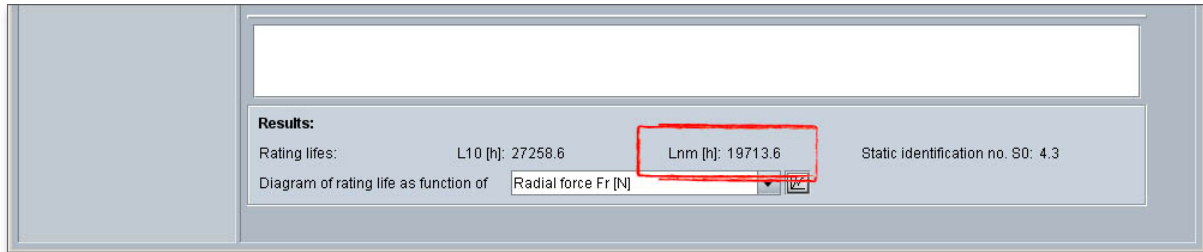

Figure 11: Modified rating life

The result of the modified rating life is $L_{nm} = 19,713.6$ h. Finally, the modified rating life L_{nm} is in the range of the rating life L_{10} .

Hinweis: Press the 'Up' and 'Down' arrow to move through the listbox of cleanliness parameters. Moving through the listbox changes the modified rating life and the results will be displayed immediately in the result panel, making it very easy to compare the modified rating life with different levels of cleanliness. You can also navigate through the lubricant listbox.

Diagrams

Click on the button 'Diagram' next to the listbox. The diagram includes the values for the rating life and for the modified rating life. The exact values can be selected directly from the graphical representation. Clicking the 'Close' button leads you back to the main mask and you can open another diagram. Use the 'Options' button to specify which diagrams should be displayed in your calculation report.

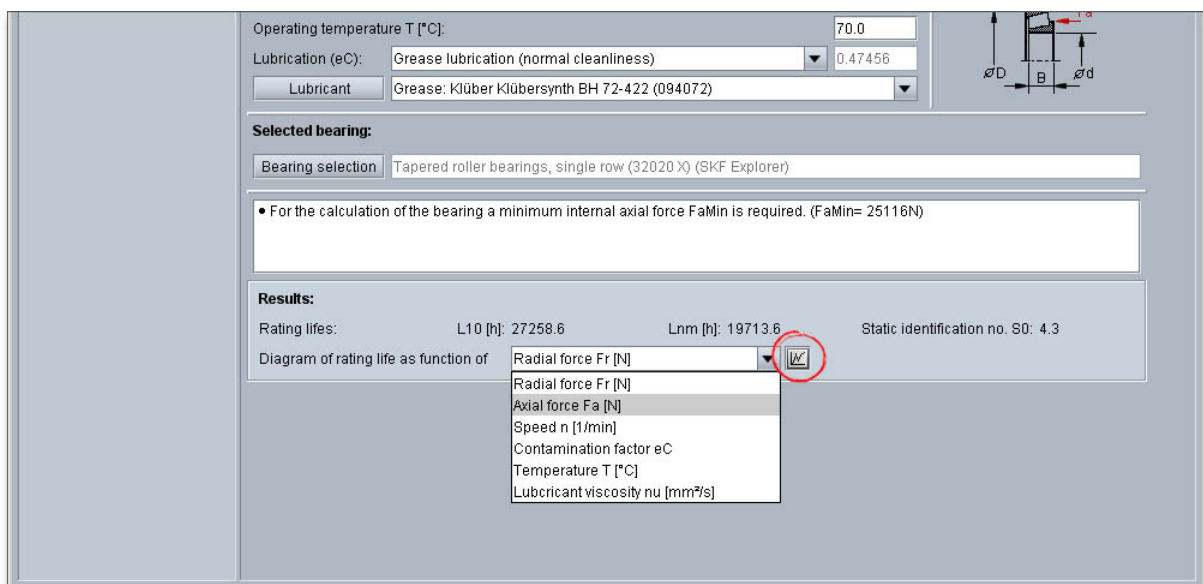

Figure 12: Button 'Diagram'

0.1.5 Documentation: Calculation Report

After the completion of your calculation, you can create a calculation report. Click on the 'Report' button.

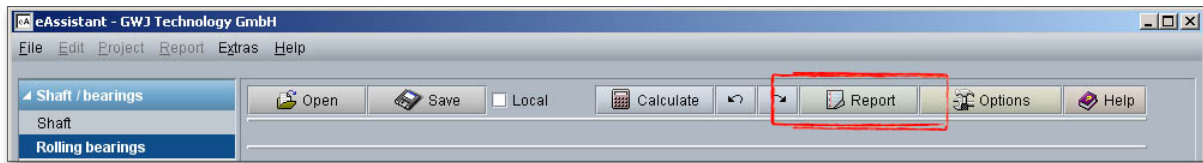

Figure 13: Button 'Report'

You can navigate through the report via the table of contents that provides links to the input values, results and figures. This calculation report contains all input data, the calculation method as well as all detailed results. The report is available in HTML and PDF format. The calculation report saved in HTML format, can be opened in a web browser or in Word for Windows.

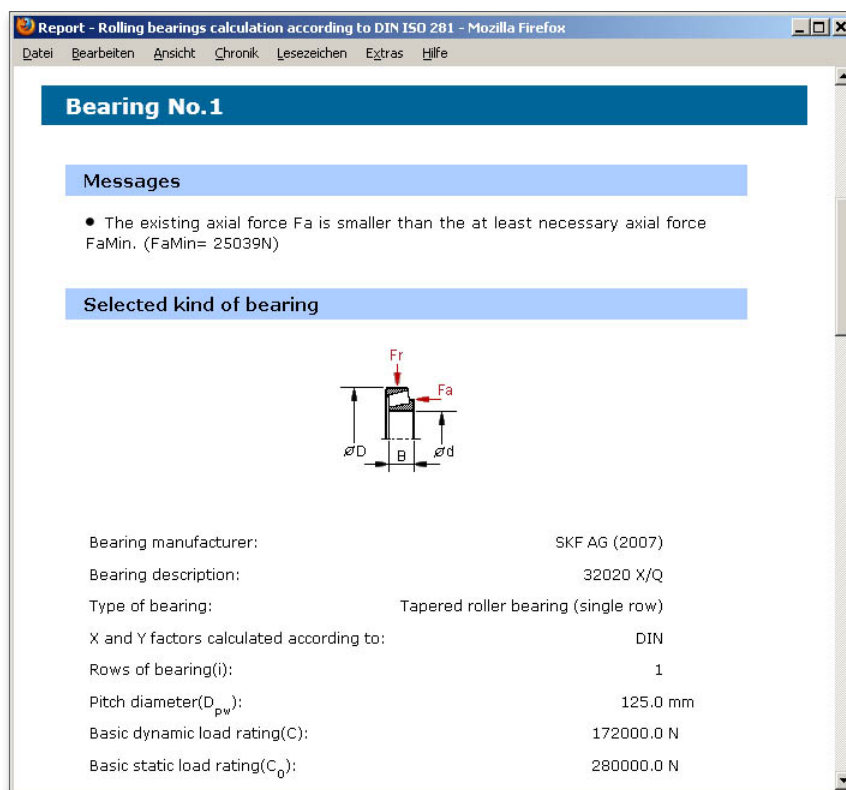

Figure 14: Calculation report

You may also print or save the calculation report:

- To save the report in the HTML format, please select 'File' → 'Save as' from your browser menu bar. Select the file type 'Webpage complete', then just click on the button 'Save'.
- If you click on the symbol 'Print', then you can print the report very easily.
- When you click on the symbol 'PDF', then the report appears in the PDF format. If you right-click on the PDF symbol, you should see the 'Save Target As' option. Click on that option and you will see the dialog box for saving the report.

0.1.6 Save the Calculation

When the calculation is finished, it is easy to save the calculation. You can save the calculation to your computer. Click the button 'Save'.

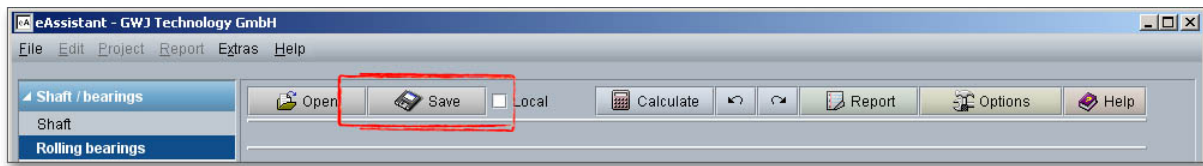

Figure 15: Button 'Save'

Please enter a name into the input field 'Filename' and click on the button 'Save'.

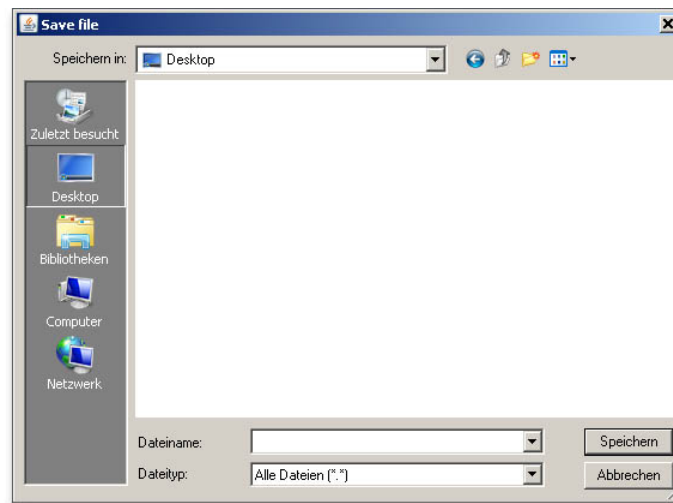

Figure 16: Windows dialog for saving the file

0.1.7 Second Calculation Example

Bearing of a Fan

The impeller of fans can be arranged either between two bearings or in an overhung position. The impeller of small and medium-sized fans is generally overhung. Two separated plummer block housings are suitable for supporting the fan drive shaft.

This calculation example we have taken from: J. Braendlein: Die Waelzagerpraxis: Handbuch zur Berechnung und Gestaltung von Waelzlagern (1995, p. 516-520, figures: p. 517).

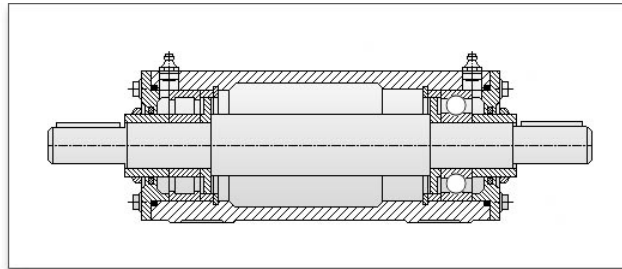

Figure 17: Bearing unit for fan

The unit (figure 17) contains a cylindrical roller bearing A and a deep groove ball bearing B in one housing (figure 18). The bearing diameter is 70 mm.

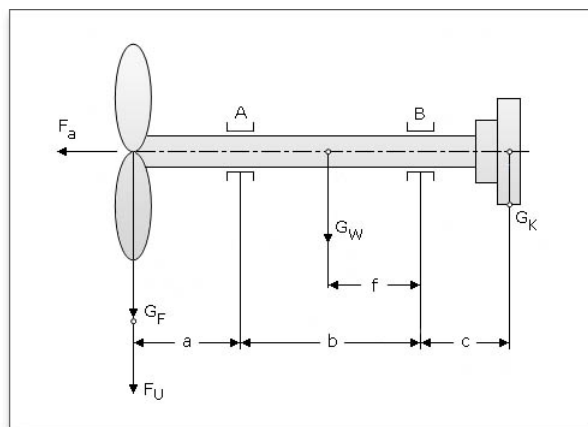

Figure 18: Bearing of a fan

Input Values

The input values for bearing A (Cylindrical roller bearing NU 314 ECP)

Load Case No. 1

Time slice q_1	= 50 %
Speed n_1	= 3000 min ⁻¹
Radial force F_{r1}	= 8500 N
Axial force F_{a1}	= 0 N
Temperature T_1	= 70 °C

Load Case No. 2

Time slice q_2	= 50 %
Speed n_2	= 4500 min ⁻¹
Radial force F_{r2}	= 11000 N
Axial force F_{a2}	= 0 N
Temperature T_2	= 70 °C

All input values for bearing B (deep groove ball bearing 6314)

Load Case No. 1

Time slice q_1 = 50 %
 Speed n_1 = 3000 min⁻¹
 Radial force F_{r1} = 2000 N
 Axial force F_{a1} = 5000 N
 Temperature T_1 = 70 °C

Load Case No. 2

Time slice q_2 = 50 %
 Speed n_2 = 4500 min⁻¹
 Radial force F_{r2} = 5000 N
 Axial force F_{a2} = 5000 N
 Temperature T_2 = 70 °C

0.1.8 The Calculation

Define the Number of Bearings

In this example we want to calculate the rating life of the cylindrical roller bearing and the deep groove ball bearing. We have to different bearings and we need to change the number of bearings. So enter 2 into the input field 'Number of bearings to calculate'. Please calculate the bearings one after another separately. The listbox 'Current view' allows you to switch between the two bearings.

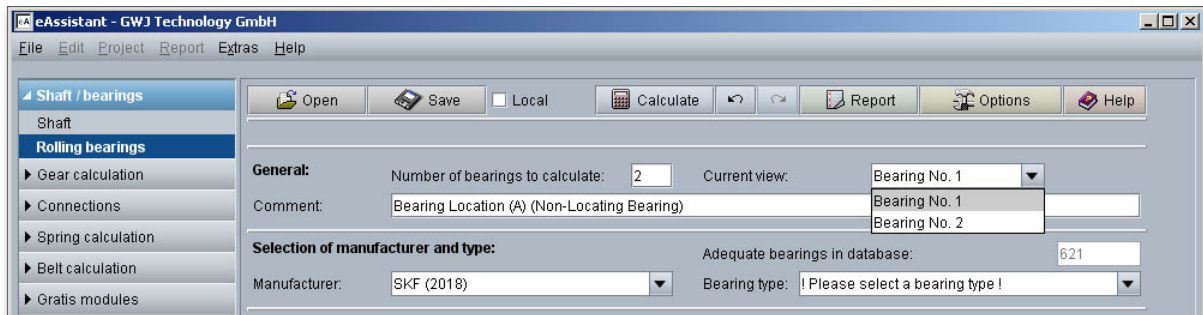

Figure 19: Number of bearings and add a comment

Add a comment for the first bearing.

Select Manufacturer and Bearing Type

Now select the manufacturer SKF. Choose the cylindrical roller bearing from the listbox.

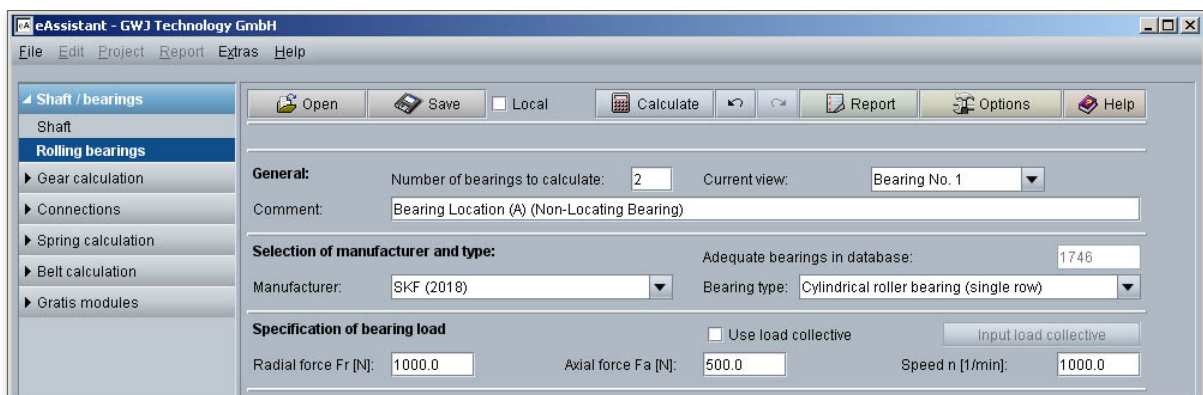

Figure 20: Selection of the manufacturer and bearing type

Specification of Bearing Load with Load Collectives

Define the load collective for the first bearing. Activate the option 'Use load collective'. The input options for the radial and axial force as well as for the speed will be deactivated. Define two load cases for the bearing. Enter the time slice, the radial force, axial force, the temperature and cleanliness for each load case. After you made all entries, click the button 'OK' to confirm your inputs.

No. of loading cases:	2						
	Time slice q [%]	Speed n [1/min]	Radial force Fr [N]	Axial force Fa [N]	Temperature T [°C]	Lubrication / Contamination factor eC	
1	50.0	3000.0	5800.0	0.0	70.0	Grease lubrication (normal cleanliness)	---
2	50.0	4500.0	11000.0	0.0	70.0	Grease lubrication (normal cleanliness)	---
---	---	---	---	---	---	---	---
---	---	---	---	---	---	---	---
---	---	---	---	---	---	---	---
---	---	---	---	---	---	---	---
---	---	---	---	---	---	---	---
---	---	---	---	---	---	---	---
---	---	---	---	---	---	---	---
---	---	---	---	---	---	---	---

Figure 21: Define the load collective

Bearing Selection

Click on the button 'Bearing selection'. It is increasingly convenient to use the search filter to quickly find the bearing you are looking for. Enter 70 mm for the inner diameter and click the button 'Search'. Now you can choose the cylindrical roller bearing NU 314 ECP from the list. Clicking the button 'OK' confirms the bearing and leads you back to the main mask.

Bearing selection search

Inner diameter of bearing d [mm]: from 70.0 to 70.0
 Outer diameter of bearing D [mm]: from any to any
 Bearing width B [mm]: from any to any
 popular item ?

Basic rating life L10 [h]: from any to any
 Modified rating life Lnm [h]: from any to any
 Max. reference speed [1/min]: from any to any
 Max. limiting speed [1/min]: from any to any

* SKF Explorer bearing

Found bearings (63):

Description	d [mm]	D [mm]	B [mm]	L10 [h]	Lnm [h]	nRef	nLim
NU 214 ECP*	70.0	125.0	24.0	30743.8	1537189.1	6000.0	6300.0
N 314 ECM*	70.0	150.0	35.0	188391.8	9419591.8	4800.0	5600.0
NU 314 ECP*	70.0	150.0	35.0	188391.8	9419591.8	4800.0	5600.0
NU 1014 ECP	70.0	110.0	20.0	4407.9	81917.9	7000.0	7000.0
NU 1014 ML	70.0	110.0	20.0	1567.6	11012.4	7000.0	11000.0
NU 214 ECJ*	70.0	125.0	24.0	30743.8	1537189.1	6000.0	6300.0
NU 214 ECM*	70.0	125.0	24.0	30743.8	1537189.1	6000.0	6300.0

Bearing details

User defined Comment: ---

Type: Cylindrical roller bearing (single row) C [N]: 236000.0
 Calculation method: DIN C0 [N]: 228000.0
 Rows of bearing: Single row f0: 0.0
 Specify X and Y X: 1.0 Y: 0.0
 Specify X0 and Y0 X0: 1.0 Y0: 0.0
 Specify alpha Alpha [°]: 0.0 Dpw [mm]: 110.0
 Specify Cu Cu [N]: 29000.0

Figure 22: Bearing selection

0.1.9 Calculation Results

Rating Life of the Cylindrical Roller Bearing (Bearing Location A)

All results will be calculated during every input and will be displayed in the result panel. A recalculation occurs after every data input. Any changes that are made to the user interface take effect immediately. First, you get the result for the rating life as well as the static identification number.

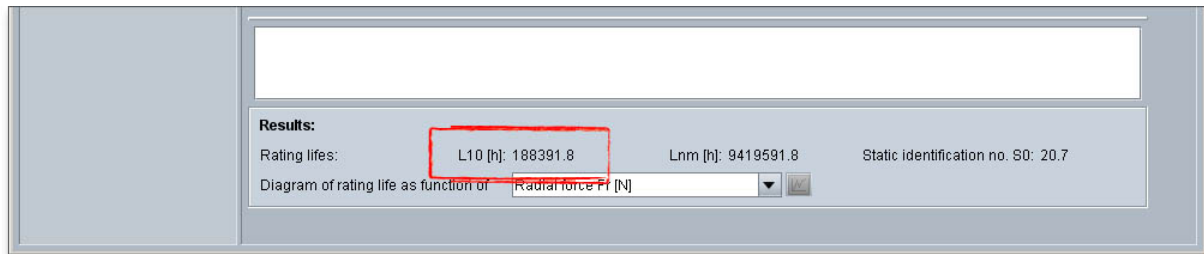

Figure 23: Rating life

The result of the rating life is $L_{10} = 188,391.8$ h

The cylindrical roller bearing is sufficiently dimensioned.

Rating Life for the Deep Groove Ball Bearing (Single Row) (Bearing Location B)

Calculate now the rating life for the deep groove ball bearing. Please pay attention that you select 'Bearing No. 2' from the listbox 'Current view'. Select the manufacturer SKF and the bearing type Deep groove ball bearing (single row).

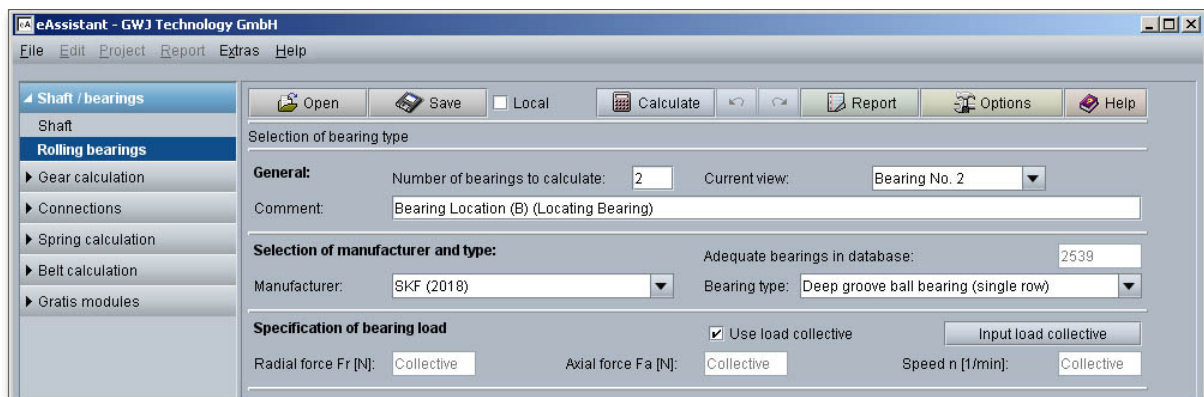

Figure 24: Bearing selection

Activate the option 'Use load collective' and define the load cases. After you made all entries, click the button 'OK' to confirm your inputs.

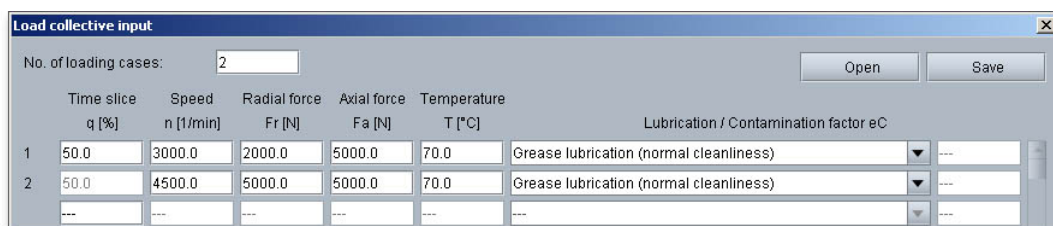

Figure 25: Define the load collective'

Click on the button 'Bearing selection'. Choose the bearing 6314* from the list. It is increasingly convenient to use the search filter to quickly find the bearing you are looking for. Enter 70 mm for the inner diameter and click the button 'Search'. Then you can select the bearing 6314 from the list. Clicking the button 'OK' confirms the bearing and leads you back to the main mask.

Bearing selection search

Inner diameter of bearing d [mm]: from 70.0 to 70.0
 Outer diameter of bearing D [mm]: any to any
 Bearing width B [mm]: any to any
 popular item ?

Basic rating life L10 [h]: any to any
 Modified rating life Lnm [h]: any to any
 Max. reference speed [1/min]: any to any
 Max. limiting speed [1/min]: any to any

* SKF Explorer bearing

Search

Found bearings (53):

Description	d [mm]	D [mm]	B [mm]	L10 [h]	Lnm [h]	nRef	nLim
6214-2RS1*	70.0	125.0	24.0	1478.3	25225.6	-	3400.0
6214-2Z*	70.0	125.0	24.0	1478.3	25225.6	11000.0	5600.0
6314*	70.0	150.0	35.0	5928.1	217108.9	9500.0	6300.0
6314-2RS1*	70.0	150.0	35.0	5928.1	217108.9	-	3000.0
6314-2Z*	70.0	150.0	35.0	5928.1	217108.9	9500.0	5000.0
61814	70.0	90.0	10.0	22.1	63.3	15000.0	9000.0
61814-2RS1	70.0	90.0	10.0	22.1	63.3	-	4300.0

Bearing details

User defined Comment: ---

Type: Deep groove ball bearing (single row) C [N]: 111000.0 Specify X and Y X: 0.56 Y: 1.5779
 Calculation method: DIN C0 [N]: 68000.0 Specify X0 and Y0 X0: 0.6 Y0: 0.5
 Rows of bearing: Single row f0: 13.2 Specify alpha Alpha [°]: 0.0 Dpw [mm]: 110.0
 Bearing clearance: CN (normal) Specify Cu Cu [N]: 2800.0

SKF Online Catalogue OK Cancel

Figure 26: Deep groove ball bearing

The result for the rating life is $L_{10} = 5,928.1$ h

Modified rating life theory Use modified rating life theory

Requisite reliability S [%]: 90.0
 Operating temperature T [°C]: ---
 Lubrication (eC): ---
 Lubricant: Oil: Standard ISO VG 220

Selected bearing:
 Bearing selection: Deep groove ball bearing, single row (6314) (SKF Explorer / popular item)

Results:
 Rating lives: L10 [h]: 5928.1 Lnm [h]: 217108.9 Static identification no. S0: 12.4
 Diagram of rating life as function of: Radial force Fr [N]

Figure 27: Nominal rating life

The rating life of the deep groove ball bearing B is lower than the rating life of the cylindrical roller bearing A. This means that bearing B is subjected to higher stresses than bearing A. At least 220,000 hours are required for the rating life of deep groove ball bearings. But with this result, the rating life is not sufficiently dimensioned. It is necessary to take a closer look at the modified rating life L_{nm} of bearing B.

Modified Rating Life of the Deep Groove Ball Bearing

The next step is to determine the modified rating life for the deep groove ball bearing. The option 'Use modified rating theory' is activated by default. Select the grease Lubcon Turmogrease Highspeed L 252 (K HC P 2/3 K-50) from the listbox or click on the button 'Lubricant' to open the lubricant selection. Choose the lubricant and confirm with the button 'OK'.

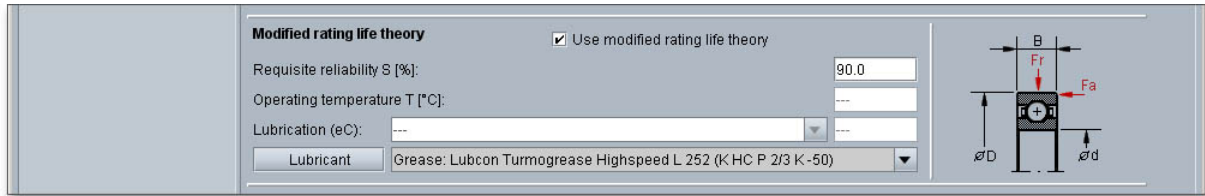

Figure 28: Modified rating life

The result of the modified rating life is $L_{nm} = 49,223.4$ h.

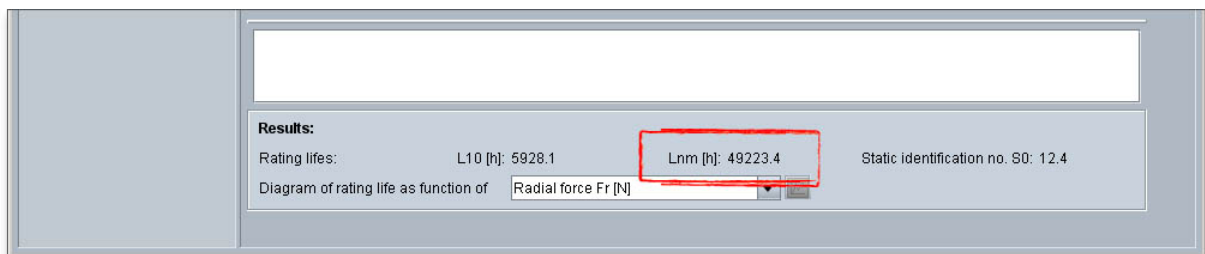

Figure 29: Result for the modified rating life

At least 22,000 hours are required and the bearing is sufficiently dimensioned. For the calculation with load collectives, you cannot open all diagrams. But you can open the diagram for the lubricant viscosity.

0.1.10 Documentation: Calculation Report

After the completion of your calculation, you can create a calculation report. Click on the 'Report' button. Click the button 'Options' and activate the diagram for the 'Lubricant viscosity'. This diagram will then appear in the calculation report.

Calculation results	
Operating viscosity (ν):	49.498 mm ² /s
Reference viscosity (ν_{1}):	6.396 mm ² /s
Viscosity ratio (κ):	4.0
Fatigue limiting load (from database) (C_U):	29000.0 N
Rating life factor for reliability (a_1):	1.0
Rating life factor (a_{ISO}):	50.0
Radial load factor (X):	1.0
Axial load factor (Y):	0.0
Static radial load factor (X_0):	1.0
Static axial load factor (Y_0):	0.0
Max. available static equivalent load (P_0):	11000.0 N
Dynamic equivalent load (from load collective) (P):	9654.696 N
Frictional torque M (M):	500.5 Nmm

Figure 30: Calculation report

You can navigate through the report via the table of contents that provides links to the input values, results and figures. This calculation report contains all input data, the calculation method as well as all detailed results. The report is available in HTML and PDF format. The calculation report saved in HTML format, can be opened in a web browser or in Word for Windows. You may also print or save the calculation report:

- To save the report in the HTML format, please select 'File' ⇒ 'Save as' from your browser menu bar. Select the file type 'Webpage complete', then just click on the button 'Save'.
- If you click on the symbol 'Print', then you can print the report very easily.
- When you click on the symbol 'PDF', then the report appears in the PDF format. If you right-click on the PDF symbol, you should see the 'Save Target As' option. Click on that option and you will see the dialog box for saving the report.

0.1.11 Save the Calculation

When the calculation is finished, it is easy to save the calculation. You can save the calculation to your computer. Click the button 'Save'. Please enter a name into the input field 'Filename' and click on the button 'Save'.

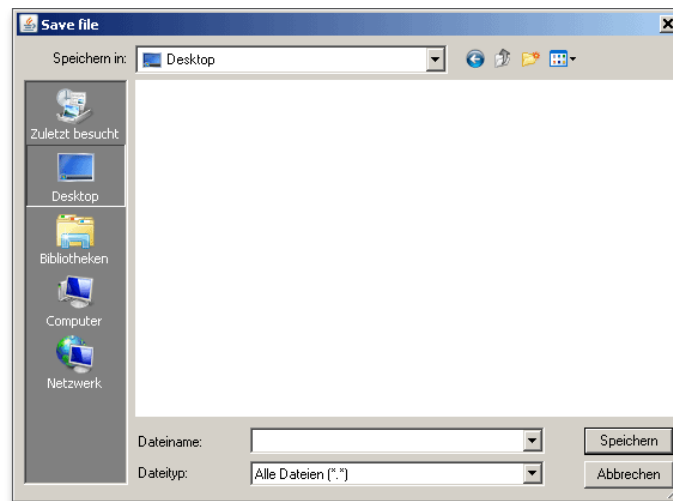

Figure 31: Windows dialog for saving the file

Our manual is improved continually. Of course we are always interested in your opinion, so we would like to know what you think. We appreciate your feedback and we are looking for ideas, suggestions or criticism. If you have anything to say or if you have any questions, please let us know via telephone +49 (0) 531 129 399-0 or email info@tbksoft.eu.